



PIKO

Catalog

2022





Factory and model photos: Falk Hummel
(www.foto-hummel.de)

A special thanks to the following families:
F. Sauerteig of Sonneberg, H. Müller of Schichtshöhn and Hynek
of Schalkau, as well as Eisenbahnwelten Rathen
(www.eisenbahnwelten-rathen.de) for their gracious assistance
with catalog images.

© 2022, PIKO Spielwaren GmbH

Dear PIKO G-Scale Friends:

This is indeed a fascinating hobby! Whether you're just getting started, or you've been building your own railroad empire for many years, we're happy to welcome you into the world of PIKO G-Scale trains and accessories for 2022. We hardly thought it possible, that the garden railroad and G-Scale train hobby could grow so much in 2021, but thanks to people like you, it grew by leaps and bounds. And that kept your PIKO team very busy, bringing record numbers of products to market and staying in touch with so many PIKO fans.

Across North America and around the world, we've seen how much people love to share their garden railroading hobby with others, and build new friendships right along with building a railroad. And one thing our PIKO friends share with us frequently is their wishes and dreams for new PIKO products. That continued input is very important to our efforts in developing new products, for 2022 and beyond. This catalog presents more than 50 exciting G-Scale new items for the year. And rest assured, there are still many more surprise new items yet to be revealed later in the year!

2021 brought some much-appreciated additions to the PIKO G-Track program, the completely new R3 switches, to fit with our R3 curves, which are almost exactly six feet in diameter. It was fitting that the PIKO brand brought you these industry-firsts, which fill a big need in the market for mid-size switches. These have already found homes on countless G-Scale railroads.

Of course, we also brought you plenty of exciting new trains throughout the past year, from the unique German "Glass Train" to elaborately

decorated Mogul locomotives recalling colorful railroading history - from the mighty Pennsylvania Railroad to the storied Union Pacific. But enough about what we've done recently! Here are some brief highlights of what's coming down the tracks in 2022 from PIKO:

For fans of German trains, steam will reign once again with the impressive new model of the big BR 94 steam loco. PIKO engineering allows those 10 drive wheels to run smoothly around even the smallest R1 curves. And the selection of locos factory-equipped with decoders and digital sound will expand this year as well.

Among other things, American railroad fans will be treated to another industry-first from PIKO – our popular 25-Ton diesel locos, now factory-equipped for onboard battery-powered operation, with built-in radio control from our easy-to-use PIKO R/C, plus all-new and incredibly realistic, powerful digital sound. These locos are truly marvels of engineering, squeezing all this technology into such a compact space. And they will come decorated in a variety of "flavors" to suit many tastes.

Speaking of decoration, our advanced technology for placing stunning color graphics on our trains has been impressing people for years, with things like our much-loved Christmas and Halloween cars. And our Vintage Warbirds series, which has been wildly popular in the past couple years, will continue expanding in 2022. We've been particularly touched to hear so many wonderful stories from PIKO fans about family members and friends who were associated with certain planes.

Before this catalog even went to press, beautiful new Easter hopper cars were on the way from Germany to America, so they could be available in time to carry loads of eggs or candy. And the American Traditions series which started in late 2021 will also grow this year. These cars feature varied themes from American history, like the Declaration of Independence, to railroad folk heroes like John Henry, to that most American of all sports, baseball.

Because PIKO fans have widely varying interests, PIKO products provide something to appeal to many different personalities. And just as the idea of a train running around a track brings people together, some common threads bind all those varied PIKO products together. Each one features a certain unmistakable PIKO combination of artistry, technology, craftsmanship and value. The PIKO name on the package is the first hint that something special is inside, because our customers and friends have come to expect nothing less.

It takes a veritable army to bring the requests of PIKO fans to life, and deliver them to your railroad. On behalf of the hundreds of PIKO employees in America, Germany and worldwide, we invite you to page through your PIKO catalog and envision the G-Scale railroad of your dreams!

Andrea, Ortrun and Dr. René F. Wilfer

Ortrun D. Wilfer

Andrea Wilfer

Dr. René F. Wilfer



STARTER SETS

PIKO G-TRACK

LOCOMOTIVES

CARS

PIKO R/C, PIKO-DIGITAL

ACCESSORIES

MODEL BUILDINGS

STARTER-SETS 9

PIKO G-TRACK 19

Geometry 20
 System 20
 Straight tracks 24
 Curved tracks..... 25
 Switches..... 26
 Accessories 29
 Track sets 32

LOCOMOTIVES 35

American Diesel Locomotives 36
 American Steam Locomotives 38
 European Steam Locomotives 44
 European Electric Locos 52
 European Diesel Locomotives 58
 Railbuses 65

CARS 67

American Passenger Cars 68
 European Passenger Cars 75
 American Freight Cars 84
 European Freight Cars 99

PIKO POWER & ACCESSORIES 107

PIKO R/C..... 108
 PIKO Analog DC Power..... 111
 PIKO Digital-System..... 112
 PIKO SmartProgrammer & Tester..... 114
 PIKO SmartDecoder 5.1 115
 Sound..... 116





















ACCESSORIES 117









Service Parts 117
 Lighting and Gearboxes 120
 Maintenance and Track Cleaning..... 121

MODEL BUILDINGS 123

Building Kits 124
 Pleasantown Building Kits 170
 Built-Ups 172
 Christmas Buildings 178
 Pleasantown Christmas Kits..... 179
 Accessories 180
 Index 185

Signs & Symbols

-  Direct current
-  DC/DCC Decoder-Equipped
-  Digital decoder-ready
-  Length over buffers
-  Weight
-  Directional Lights
-  Directional lights white/red
-  Directional Lights LEDs
-  Directional lights white/red LEDs
-  Directional lights red/red LEDs
-  Interior Lighting-ready
-  Interior Lighting
-  Running gear lights
-  Number of motors
-  Ball bearing motor
-  Smoke Unit - ready
-  Smoke Unit-Equipped
-  Number of traction tires
-  Recommended minimum radius
-  Hard-chromed wheels
-  Ball bearing, hard-chromed wheels

-  Metal wheel sets for Cars available
-  Sound-ready
-  Sound-Equipped
-  Radio Control
-  incl. PSD XP 5.1
-  incl. PSD XP 5.1 Sound
-  End of Range (available as long as stocks last)
-  Limited Availability (as long as stock lasts)

Railways

- B, SNCB** Belgian State Railway
- CFL** Luxembourg State Railway
- DB** German Federal Railway
- DB AG** German Federal Railway Inc.
- DR** German Imperial Railway,
- NS** Dutch State Railway
- ÖBB** Austrian Federal Railway
- PKP®** Polish State Railway
- RENFE** Spanish State Railway
- SBB** Swiss Federal Railway

SNCF® and PKP® are registered Trademarks. All rights reserved.

Disclaimer:

While every effort has been made to ensure the accuracy of information in this catalog, PIKO America LLC and PIKO Spielwaren GmbH assume no responsibility for any errors. Products, specifications, technical details and availability subject to change without notice.

Private Railways

- CFL Cargo** Luxemburgisches, internationales Unternehmen
- C&S** Colorado & Southern
- CTL Cargo** Trans Logistik AG
- EGP** Eisenbahngesellschaft Potsdam
- HSB** Harzer Schmalspurbahnen
- MRCE** Mitsui Rail Capital Europe B.V.
- MWB** Mittelweserbahn
- On Rail** Private Wagon-Vermietgesellschaft Mettmann
- PEG** Prignitzer Eisenbahn GmbH
- B&O** Baltimore & Ohio
- CN** Canadian National
- D&RGW** Denver & Rio Grande Western*
- NYC** New York Central
- RDG** Reading Lines
- PRR** Pennsylvania Railroad
- SF** Santa Fe
- SP** Southern Pacific*
- UP** Union Pacific Railroad Company*
- WP&YR** White Pass & Yukon Route
- WP** Western Pacific*

* Produced under trademark license from Union Pacific Railroad Company.

Periods

- I** **Period I 1835 – 1925**
First railways were built and numerous state and private railways founded.
- II** **Period II 1925 – 1945**
Founding of large state railway companies such as DRG, BBÖ or SBB. Regulations were synchronised and standards of construction established. First electric operation.
- III** **Period III 1945 – 1970**
Reconstruction and recovery from war damage to the railways. Steam locos began to be replaced by diesel and electric locos. Construction of passenger coaches and goods trucks in cooperation with other state railways.
- IV** **Period IV 1970 – 1990**
End of steam operation. Introduction of computer-oriented classifications on locos and other vehicles. Pre-war equipment taken out of service.
- V** **Period V 1990 – 2007**
Beginning of the ICE age. Fusion of DB and DR. Introduction of "traffic red". Reorganisation of the railway into business divisions. Modern locos and motor coaches taken into service.
- VI** **Period VI 2007 – today**
Besides traditional railroad companies, many private railroad transit companies also travel existing railroad networks in national and international transport with their own vehicles. Introducing the 12-digit UIC numbering system.



QUALITY HIGHLIGHTS



Separately attached grab rails

Directional constant-intensity LED lighting

Authentic and comprehensive lettering and decoration

Many models with ball bearings on driven axles and hard-chrome plated wheels for improved power pickup

Locomotives with enclosed gearboxes, precision "can" type motors and reliable gear drive for smooth, long-lasting performance.

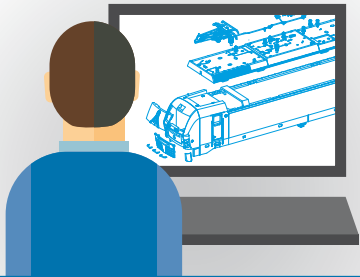

Design

Model design according to the dimensions and engineering drawings of the original.



Moldshop

Highly skilled machinists combine computer-aided milling with painstaking hand work to make hardened steel molds for plastic injection.

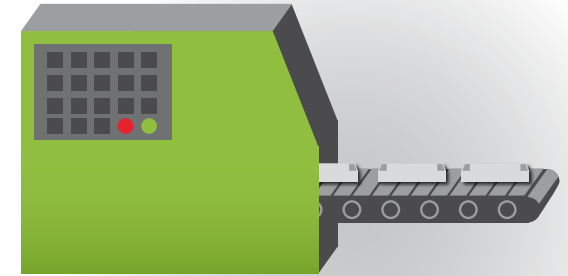

Plastic Injection

The high level of detail in today's plastic parts was unthinkable just a few years ago.



Logistics

Packing and delivery of locos and cars, tracks and buildings to retailers and customers all over the world.

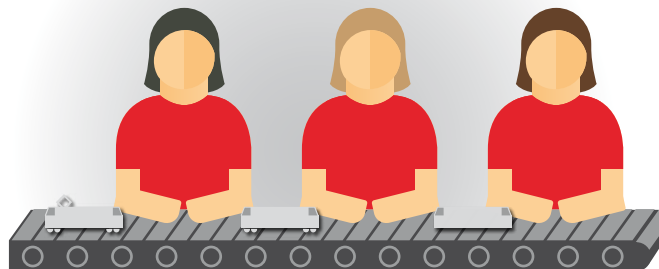

Assembly

Assembly involves fitting many delicate detail parts and multiple quality control checks.

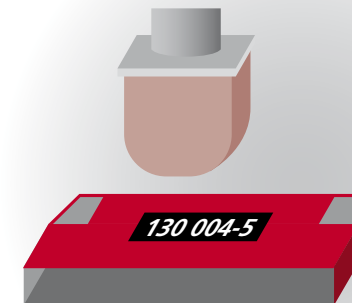

Printing

Giving a model colorful and accurate decorations often takes over 40 painting and printing steps.

STARTER SETS



STARTER SETS

- > Robust technology
- > Excellent operating characteristics
- > High degree of realism
 - > Weather-resistant materials for indoor/outdoor use
 - > Everything needed is included – Locomotive, cars, track, power supply and more



See this and more great starter sets on the following pages.



38152 North Pole Hauler R/C Starter Set



Contents 38152/38153:

- 1 x 25 Ton Diesel Loco
- 2 x Freight Cars
- 1 x R/C Track Power Controller
- 1 x Safety-Approved 120 V Transformer 24 V DC / 45 VA
- 12 x 35211 R1 (Curve Track R1 600 mm / 23.6")
- 1 x 35270 Track Power Clamp
- 1 x 35285 Track Clips, 14 pcs.
- 1 x R/C Pocket Remote

The R/C sets on these two pages include:

Starter Sets on these pages with the "PIKO R/C" designation feature a simple R/C track power controller and pocket remote for easy wireless walk-around control of train speed and direction, as well as accessory power and emergency stop. This R/C Track Power Controller can also operate other locos, with no loco modification.



38153 Halloween Hauler R/C Starter Set Includes "glow-in-the-dark" highlights





38112 D&RGW Passenger R/C Starter Set with 2 Passenger Cars and Analog Sound & Smoke

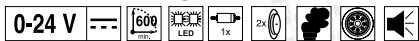

For all Starter Sets:

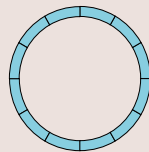

Floor area: \varnothing 51.18"
Minimum area for assembly: \varnothing 59.06"

Contents 38112/38123:

- | | |
|---|---------------------------------------|
| 1 x Steam Loco with Analog Sound | 1 x R/C Pocket Remote |
| 2 x Passenger Cars (only for 38112) | 1 x Safety-Approved 120 V Transformer |
| 3 x Freight Cars (only for 38123) | 24 V DC / 45 VA |
| 12 x 35211 R1 (Curve Track R1 600 mm / 23.6") | 1 x 36039 Uncoupling Wand |
| 1 x 35270 Track Power Clamp | 1 x Smoke Fluid (10 ml) |
| 1 x 35285 Track Clips, 14 pcs. | 2 x 35268 Track Magnets |
| 1 x R/C Track Power Controller | |



38123 Christmas Freight R/C Starter Set with 3 Freight Cars and Analog Sound & Smoke

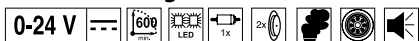



38107 PRR Freight R/C Starter Set 120V

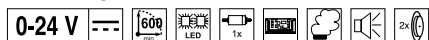

Contents 38107/38108

- 1 x Steam Loco
- 2 x Freight Cars
- 12 x 35211 R1 (Curve Track R1 600 mm / 23.6")
- 1 x 35270 Track Power Clamp
- 1 x 35285 Track Clips, 14 pcs.
- 1 x R/C Pocket Remote
- 1 x R/C Track Power Controller
- 1 x Safety-Approved 120 V Transformer 24 V DC / 45 VA

The R/C sets on these two pages include:

Starter Sets on these pages with the "PIKO R/C" designation feature a simple R/C track power controller and pocket remote for easy wireless walk-around control of train speed and direction, as well as accessory power and emergency stop. This R/C Track Power Controller can also operate other locos, with no loco modification.



38108 SF Freight R/C Starter Set 120V

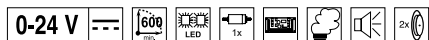

**NEW
2022**



38109 White Pass & Yukon Freight R/C Starter Set with Sound & Smoke



For all Starter Sets:

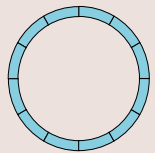

Floor area: \varnothing 51.18"
Minimum area for
assembly: \varnothing 59.06"

Contents 38109:

- | | |
|---|---------------------------------------|
| 1 x Steam Loco | 1 x R/C Track Power Controller |
| 2 x Freight Cars | 1 x Safety-Approved 120 V Transformer |
| 12 x 35211 R1 (Curve Track R1 600 mm / 23.6") | 24 V DC / 45 VA |
| 1 x 35270 Track Power Clamp | 1 x 36039 Uncoupling Wand |
| 1 x 35285 Track Clips, 14 pcs. | 1 x Smoke Fluid (10 ml) |
| 1 x R/C Pocket Remote | |





Developed in exclusive cooperation with Circus Roncalli

37154 Circus Roncalli R/C Starter Set, battery-powered



The 37154 Circus Roncalli Starter Set is completely battery-powered and includes a pocket remote for easy wireless walk-around control of train speed, direction and emergency stop. 6x 'AAA' batteries (not included, high-capacity rechargeables are recommended) give up to two hours run time. The front of the engine hood opens up for easy access to the quick-change battery clip inside.

Contents 37154:

- 1 x 25 Ton Diesel Loco
- 2 x Freight/Passenger Cars
- 12 x 35211 R1 (Curve Track R1 600 mm / 23.6")
- 1 x 35270 Track Power Clamp
- 14 x 35285 Track Clips
- 1 x R/C Pocket Remote

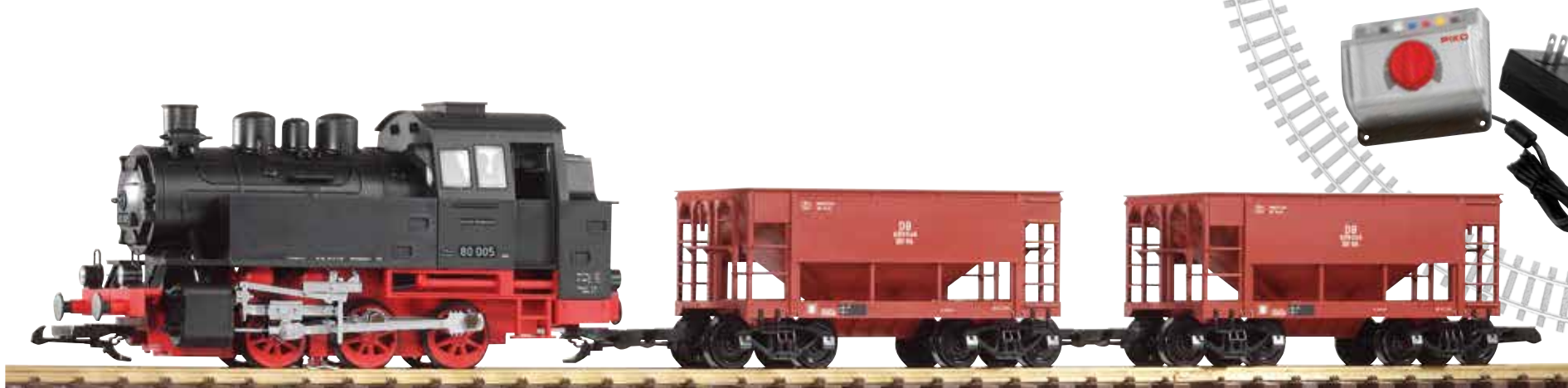

37100 DB III BR 80 Ore Starter Set

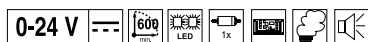

Contents 37100:

- 1 x Steam Loco
- 2 x Freight Cars
- 12 x 35211 R1 (Curve Track R1 600 mm / 23.6")
- 1 x 35270 Track Power Clamp
- 14 x 35285 Track Clips
- 1 x Analog Throttle
- 1 x Safety-Approved 120 V Transformer 24 V DC / 45 VA



38130 Classic BR 80 Steam Passenger Starter Set



Contents 38130:

- 1 x Steam Loco
- 2 x Passenger Cars
- 12 x 35211 R1 (Curve Track R1 600 mm / 23.6")
- 1 x 35270 Track Power Clamp

- 14 x 35285 Track Clips
- 1 x Analog Throttle
- 1 x Safety-Approved 120 V Transformer 24 V DC / 45 VA
- 1 x 36039 Uncoupling Wand



For all Starter Sets:

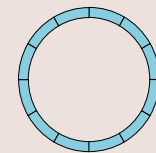

Floor area: \varnothing 51.18"
 Minimum area for assembly: \varnothing 59.06"



38151 Industrial Starter Set



Contents 38151:

- 1 x 25 Ton Diesel Loco
- 2 x Freight Cars
- 12 x 35211 R1 (Curve Track R1 600 mm / 23.6")
- 1 x 35270 Track Power Clamp

- 14 x 35285 Track Clips
- 1 x Analog Throttle
- 1 x Safety-Approved 120 V Transformer 24 V DC / 45 VA

These PIKO G-Starter Sets come complete with everything required to enter into the world of G-Scale railroading - a powerful locomotive, cars, a full circle of brass track, power hookups, throttle and safety-approved transformer. It's easy to just open the package, assemble the set (no tools needed!) and start running trains.

PIKO G trains and accessories are built of incredibly tough weather-resistant materials for years of enjoyment indoors or out.



38121 DR III V20 Freight Starter Set with Analog Sound



Contents 38121:
1 x Model car Trabant



38126 DB III V20 Passenger Starter Set with Analog Sound



Contents (for all starter sets on these two pages):

- 1 x Diesel Loco/Steam Loco
- 2 x Freight/Passenger Cars
- 12 x 35211 R1 (Curve Track R1 600 mm / 23.6")
- 1 x 35270 Track Power Clamp
- 14 x 35285 Track Clips
- 1 x Safety-Approved 120 V Transformer 24 V DC / 45 VA
- 1 x Analog Throttle
- 2 x 35268 Track Magnets
- 1 x 36039 Uncoupling Wand

For all Starter Sets:

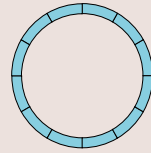

Floor area: Ø 51.18"
Minimum area for assembly: Ø 59.06"



38120 DB III BR 80 Freight Starter Set with Analog Sound and Smoke



Contents 38120:
1 x Smoke Fluid (10 ml)



38125 DR III BR 80 Passenger Starter Set with Analog Sound and Smoke

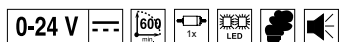

Contents 38125:
1 x Smoke Fluid (10 ml)



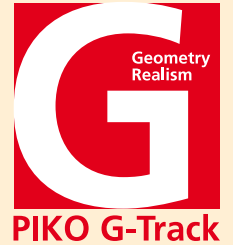

PIKO G-TRACK

- > Code 332 (0.332" high) solid rails of pure, virgin brass for excellent electrical conductivity.
- > Unique track geometry makes even complex track plans simple to build with only a few different types of track sections.
- > Unlimited possibilities due to full compatibility with track from other brands like LGB** and others.

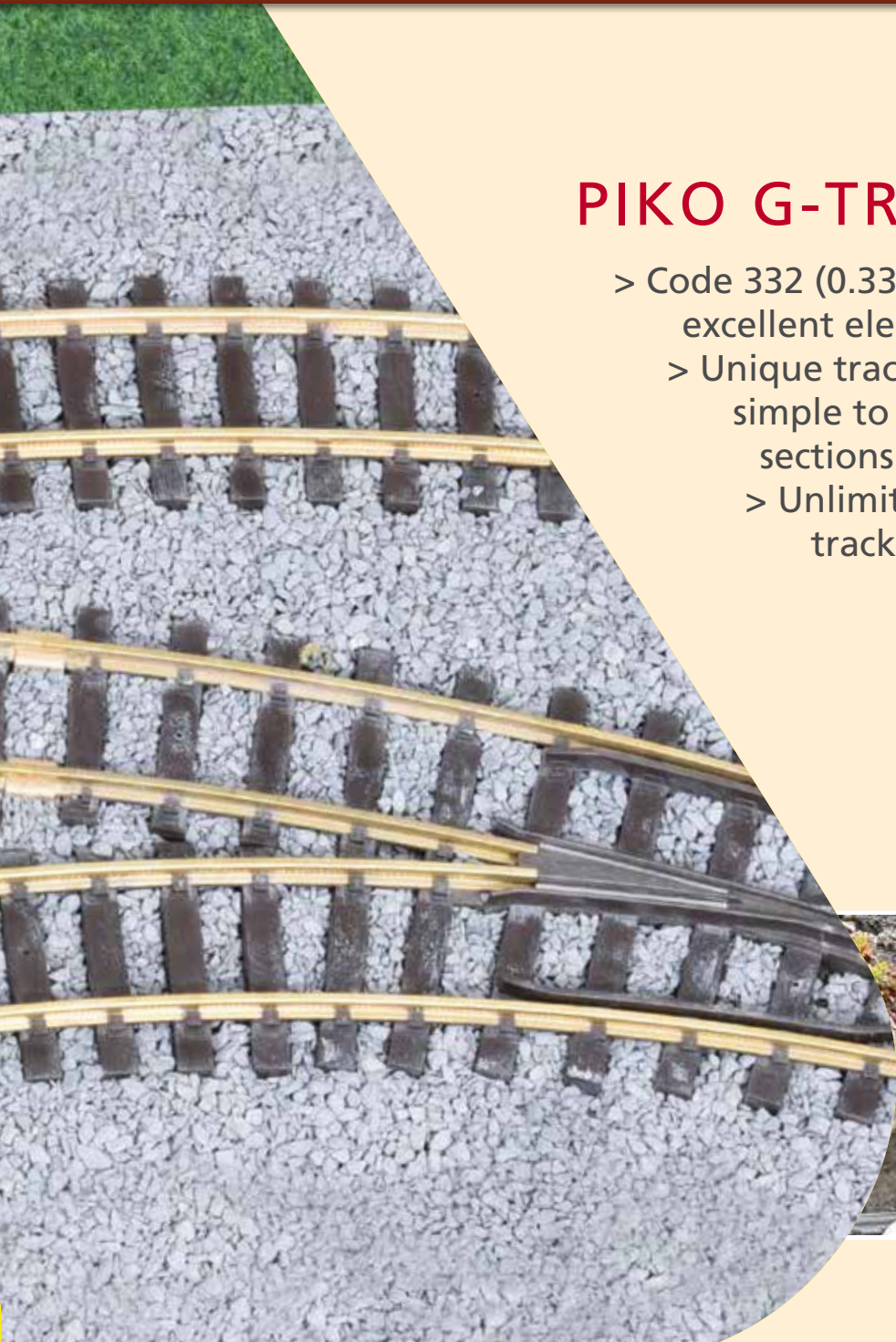

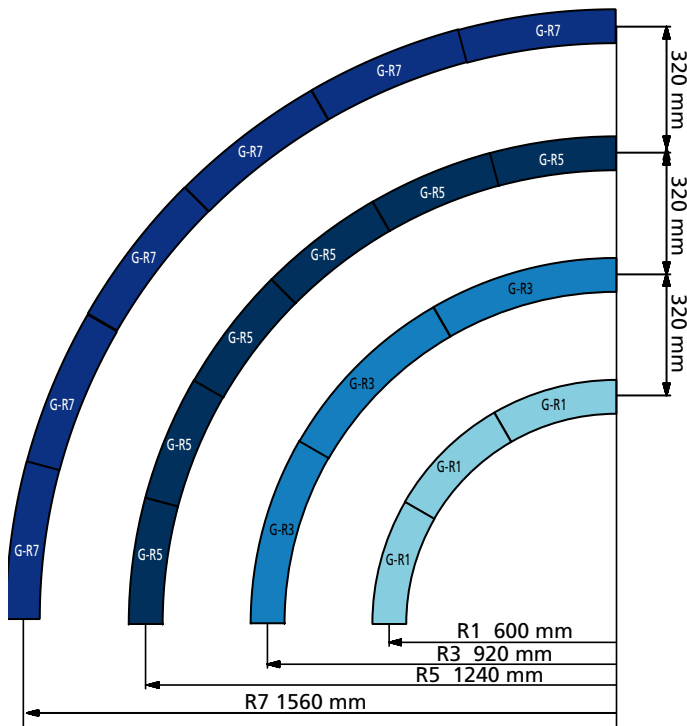
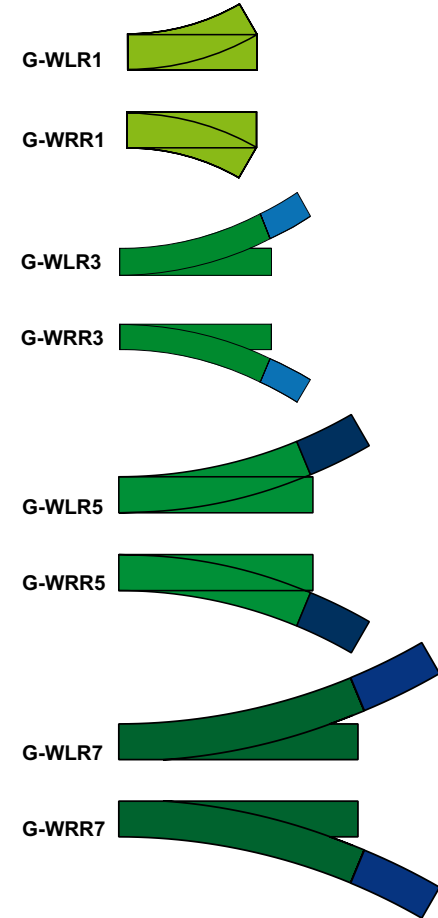
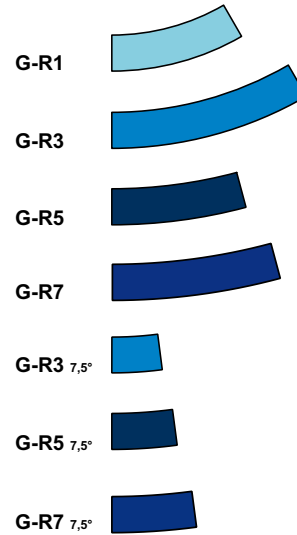
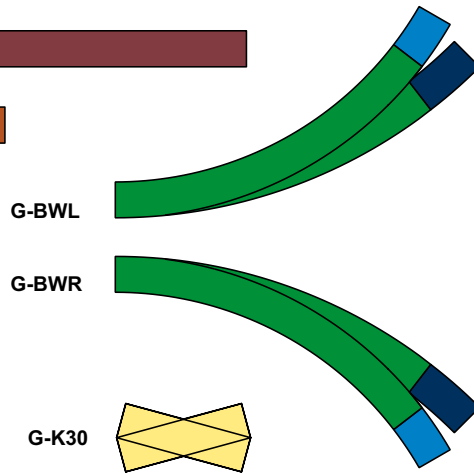
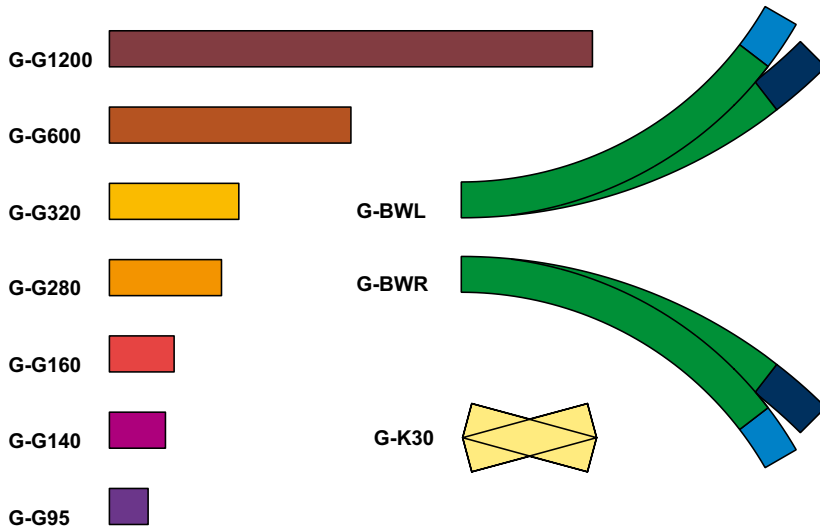

- 35200 G-G320 Straight Track, 12.66" (320 mm)
- 35201 G-G280 Straight Track, 10.96" (280 mm)
- 35202 G-G160 Straight Track, 160 mm (6.30")
- 35203 G-G140 Straight Track, 140 mm (5.48")
- 35204 G-G95 Straight Track, 95 mm (3.74")
- 35209 G-G1200 Straight Track, 47.24" (1200 mm)
- 35208 G-G600 Straight Track, 23.62" (600 mm)
- 35211 G-R1 Curved track 30°, r = 23.62" (600 mm)
- 35213 G-R3 Curved track 30°, r = 920 mm (36.28")
- 35215 G-R5 Curved track 15°, r = 1240 mm (48.94")
- 32516 G-R5 7,5° Curved track 7,5°, r = 1200 mm (48.82")
- 35218 G-R7 7,5° Curved track 7,5°, r = 1565 mm (61.60")

- 35240 G-K30 Crossing, 30°
- 35220 G-WLR1 Manual Switch, Left, R1, 30°
- 35221 G-WRR1 Manual Switch, Right, R1, 30°
- 35228 G-WLR3 Manual Switch, Left, R3, 22,5°
- 35229 G-WRR3 Manual Switch, Right, R3, 22,5°
- 35222 G-WLR5 Manual Switch, Left, R5, 22,5°
- 35223 G-WRR5 Manual Switch, Right, R5, 22,5°
- 35226 G-WLR7 Manual Switch, Left, R7, 22,5°
- 35227 G-WRR7 Manual Switch, Right, R7, 22,5°
- 35224 G-BWL Manual Curved Switch, Left
- 35225 G-BWR Manual Curved Switch, Right

The 23.62" Grid – The Starting Point

The PIKO G-Track design is based on a 23.62" x 6.30" (600 x 160 mm) grid. These dimensions were not chosen at random. They are the result of extensive computer-aided engineering with the goal to satisfy the requirements of beginners and advanced hobbyists alike.

With this grid, almost all track designs can be realized without the need for short adapter pieces. This includes elegant turnouts on the straight or on curves, as well as parallel tracks at various distances that allow the use of existing accessories, such as platforms.

The simple grid system eliminates the need for complicated design charts. Instead layouts can be designed on ordinary graph paper to determine the track elements required.

The Track Design. The outstanding feature of PIKO G-Track's design is that it only requires a small set of different track elements. Neither switches nor crossovers require the installation of short adapter pieces, which often cause uneven running and electrical contact problems.

For straight track the grid's base length of 23.62" (600 mm) is partitioned into two sections that are 12.66" (320 mm) and 10.96" (280 mm) in length. This makes it possible to have parallel tracks connected by two turnouts without any extra adapter pieces.

The Track PIKO G-Track rails are made from high quality, pure, virgin brass. The ample cross-section of solid Code 332 rail allows for optimal conductivity with minimal voltage loss, even over long distances. The brass rail joiners create a secure and durable connection between sections and ensure good electrical contact at the joints.

The ties are made of ultra-violet stabilized HDPE plastic, which is characterized by its high impact resistance, noise reduction properties and resistance to cracking under stress.

Track Identification In addition to the item number, the PIKO G-Track system uses track element names such as G-G320. These names identify the elements in the various track diagrams. In addition to its name, each track section has an associated color that is used in track diagrams, brochures, catalogs, and on the boxes. This makes it easy to identify the desired piece of track.

Straight Track The PIKO G-Track system normally requires only two straight track sections: G-G320 and G-G280. When joined these two sections form the grid's 600 mm base length. The other straight track sections, such as G-G160 and G-G140, can be used anywhere but are only necessary when creating more complex track layouts.

Flex track For construction of smooth flowing curves with any desired radius, the PIKO G-Track system also includes flex track. It is assembled from individual rails and tie strips. Using the G-SB280 and G-SB320 tie strips with the G-P1500 or G-P3000 rail sections, you can build your own flex track.

Please note: A rail bending tool is required to accurately bend the flex track to a desired radius, but long straight tracks can be easily built without tools.

The Curves The PIKO G-Track offers 4 basic radii that are spaced 320 mm apart.

G-R1 curved track 30°, r = 23.62" (600 mm)

G-R3 curved track 30°, r = 36.28" (921.54 mm)

G-R5 curved track 15°, r = 48.94" (1,243.08 mm)

G-R7 curved track 15°, r = 61.60" (1,564.62 mm)

To form a complete circle (360°), 12 curved track sections are required for the radii G-R1 and G-R3 and 24 for the radii G-R5 and G-R7. The 12.66" (320 mm) distance between tracks ensures that even on radius G-R1 and G-R3 long rolling stock can pass without interference.

Curved Track for Switches To get from a switch to a parallel track (such as on a passing siding) while maintaining the grid's base distance of 6.34" (160 mm), a single G-R1 curved track section is required.

Switches All PIKO G-Track switches can be operated as manual or electric switches. By attaching an electric switch machine, any switch easily converts to electrical operation.

Details The finely reproduced spike and bolt, which secure the rail to the tie in the original, are designed so that standard compliant wheel sets run smoothly over all elements of the PIKO G-Track.

Laying Track The sturdy, high quality, brass rail joiners ensure that PIKO G-Track can be laid on almost any surface, even indoor carpet or across a lawn in the garden.

Power Hook-up The easiest way to hook up power to the PIKO G-Track is the Power Clamp (#35270). It can be attached to any track section.

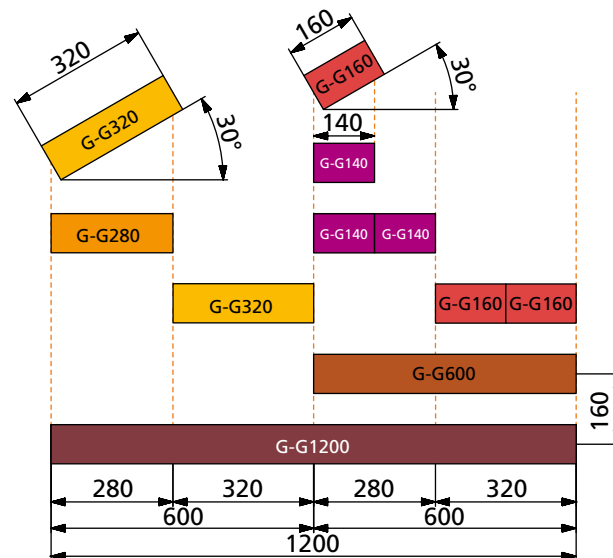

FROM ONE TRACK TO THE NEXT ...

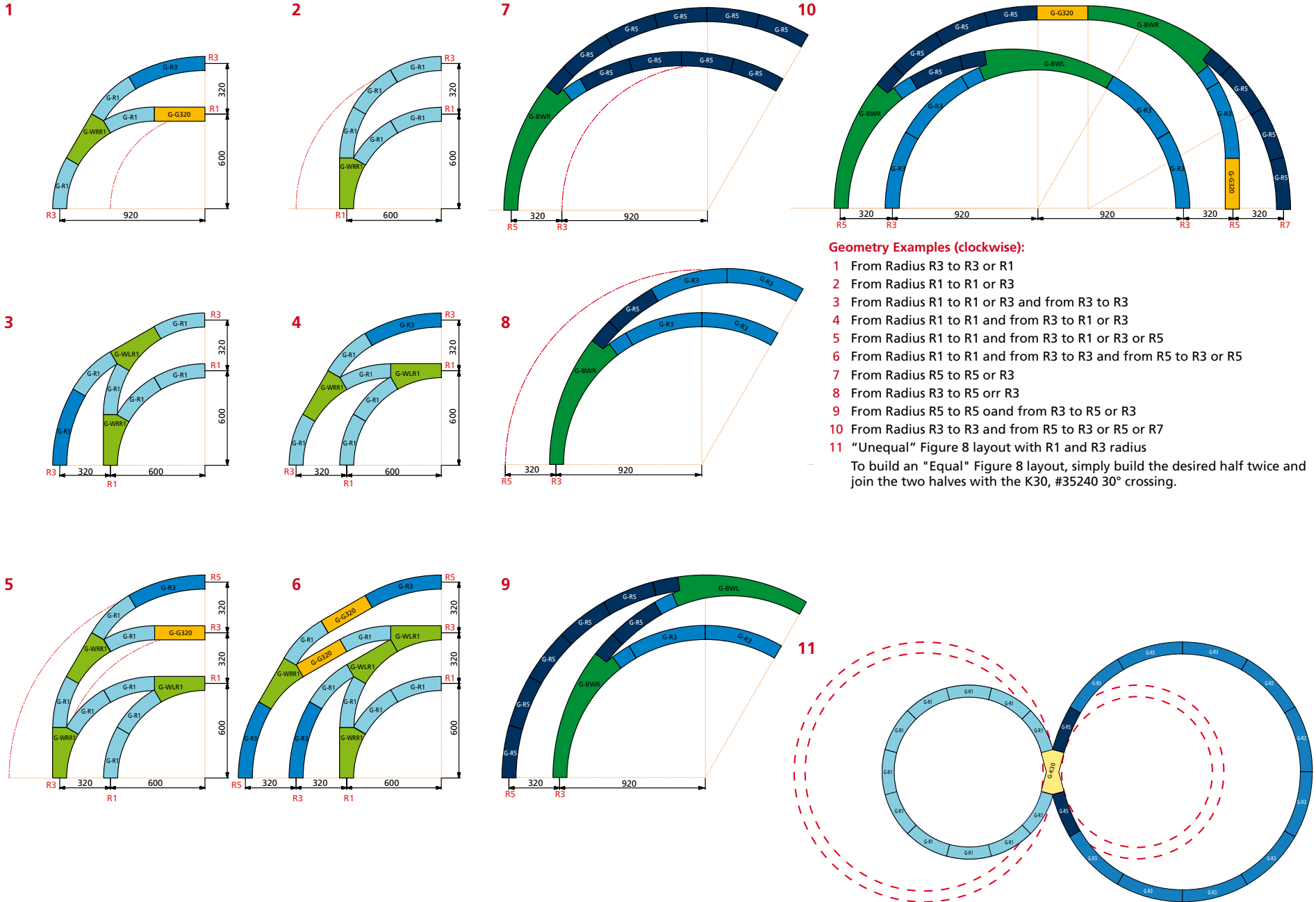

Straight Track



35200 Straight Track, 12.6" (320 mm)
Exact Length 12.66" (321.54 mm).
G-320 + G-280 make up the module length of 23.62" (600 mm)

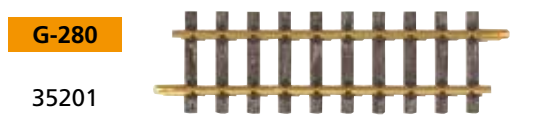

35201 Straight Track, 11" (280 mm)
Exact Length 10.96" (278.46 mm).
G-280 + G-320 make up module length of 23.62" (600 mm)

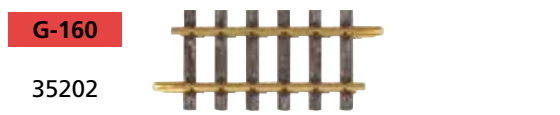

35202 Straight Track, 6.3" (160 mm)
Exact Length 6.33" (160.77 mm).
Half of the G-320 section length

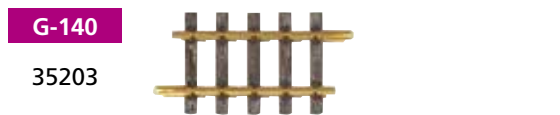

35203 Straight Track, 5.5" (140 mm)
Exact Length 5.48" (139.23 mm).
Half of the G-280 section length



35204 Straight Track, 3.75" (95 mm)
Exact Length 3.79" (96.15 mm)

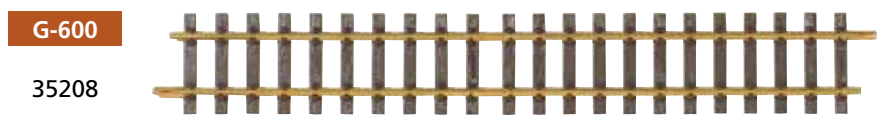

35208 Straight Track, 23.6" (600 mm)
Exact Length 23.62" (600 mm).
This is the standard PIKO G-Track module of 23.62" (600 mm)

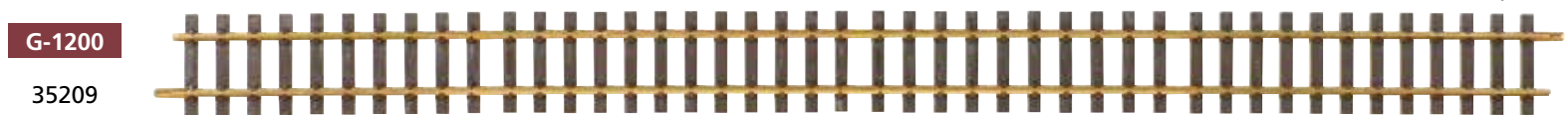

35209 Straight Track, 47.25" (1200 mm)
Exact Length 47.24" (1200 mm).
Double the standard G-Track module of 23.62" (600 mm)

CURVE TRACK SECTIONS

Curved Track

G-R1

35211

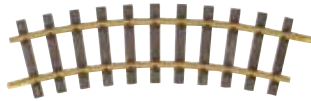

35211 Curve Track, R1 23.6" R (600 mm)

Exact Center Line Radius = 23.62" (600 mm)
30° per section / 12 sections per circle

G-R3

35213

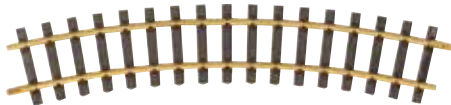

35213 Curve Track, R3 36.25" R (920 mm)

Exact Center Line Radius = 36.28" (921.54 mm)
30° per section / 12 sections per circle

G-R5

35215

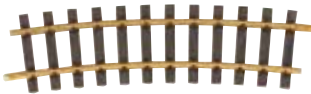

35215 Curve Track, R5 49" R (1240 mm)

Exact Center Line Radius = 48.94" (1243.08 mm)
15° per section / 24 sections per circle

G-R7

35217



35217 Curve Track, R7 61.6" R (1565 mm)

Exact Center Line Radius = 61.6" (1564.6 mm)
15° per section / 24 sections per circle

G-R3 7,5°

35214

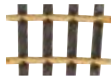

35214 Curve Track, R3 7.5° 36.25" R (920 mm)

Exact Center Line Radius = 36.28" (921.54 mm)
7.5° per section / 48 sections per circle

G-R5 7,5°

35216

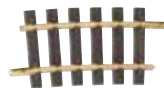

35216 Curve Track, R5 7.5° 47.25" R (1200 mm)

Exact Center Line Radius = 47.24" (1200 mm)
7.5° per section / 48 sections per circle

G-R7 7,5°

35218



35218 Curve Track, R7 7.5° 61.6" R (1565 mm)

Exact Center Line Radius = 61.6" (1564.6 mm)
7.5° per section / 48 sections per circle



Switches and Crossing

G-WLR1

35220



G-WRR1

35221

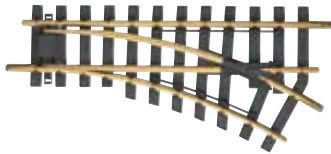

G-WLR5

35222

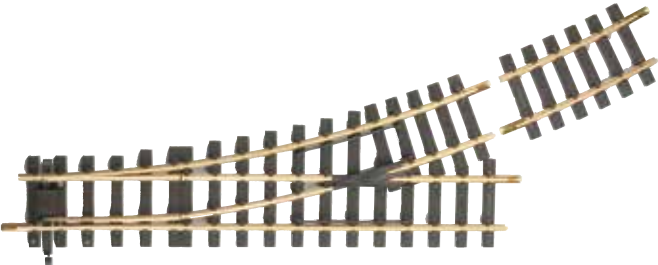

G-WRR5

35223

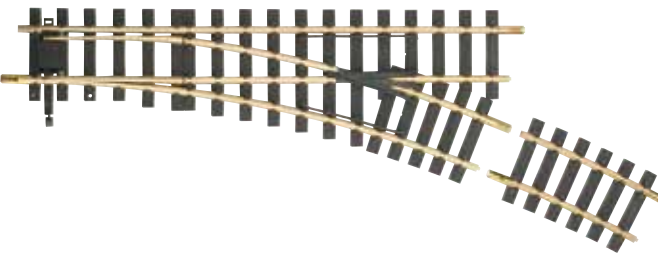

G-K30

35240



35220 Manual Switch, Left, R1, 30°

Straight track = G-320, 12.60" (320 mm)

Curved track = R1 = 23.62" (600 mm)

Compatible electric switch machine #35271

35221 Manual Switch, Right, R1, 30°

Straight track = G-G320, 12.60" (320 mm)

Curved track = R1 = 23.62" (600 mm)

Compatible electric switch machine #35271

35222 Manual Switch, Left, R5, 22.5°

Straight track = G-320 + G-160 = 18.90" (480 mm)

Curved track = 3 x Curve R5, 7.5°, 48.82" (1200 mm)

Package includes one Curve R5 7.5°

Compatible electric switch machine #35271

35223 Manual Switch, Right, R5, 22.5°

Straight track = G-320 + G-160 = 18.90" (480 mm)

Curved track = 3 x Curve R5, 7.5°, 48.82" (1200 mm)

Package includes one Curve R5 7.5°

Compatible electric switch machine #35271

35240 Crossing, 30°

Straight tracks = G320

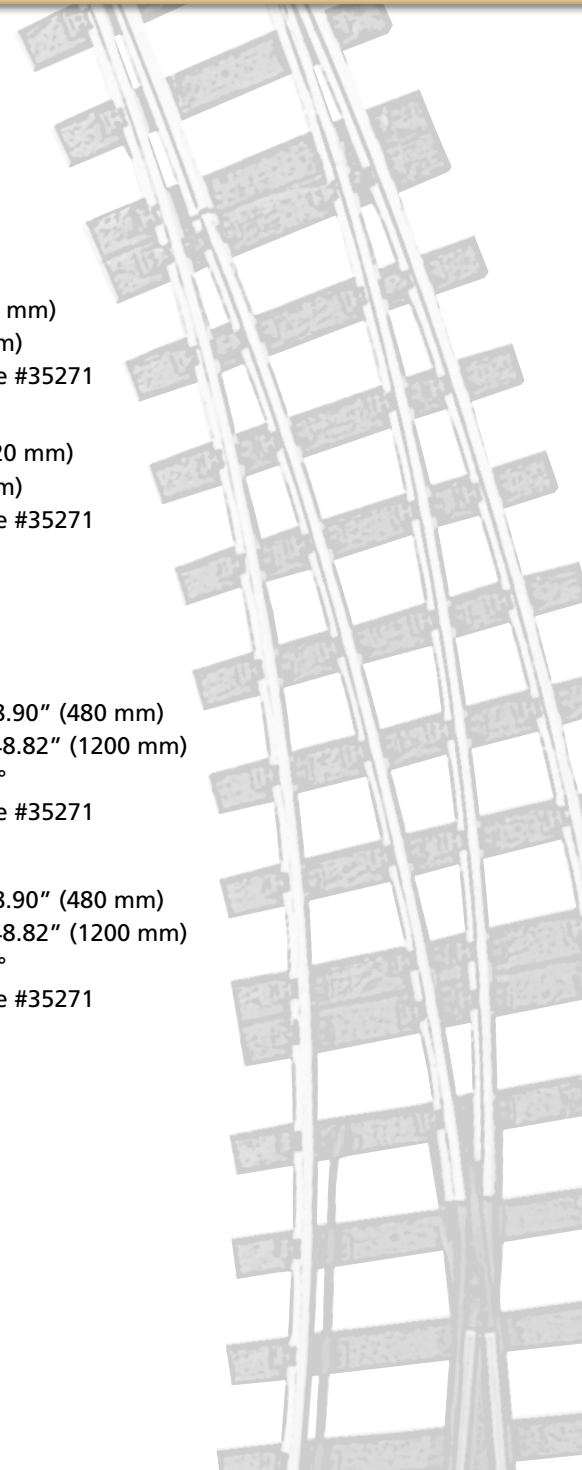

G-WLR3
35228

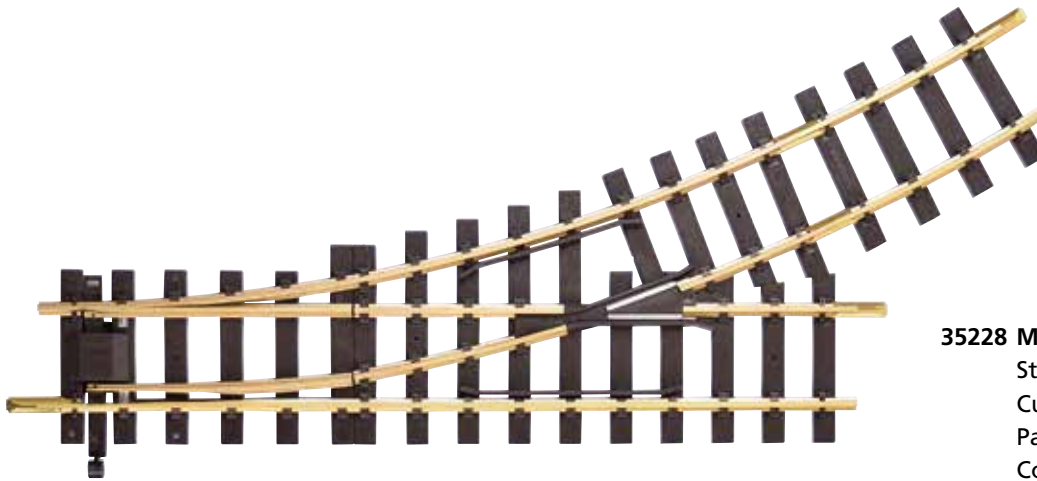

35228 Manual Switch, Left, R3, 22.5°
 Straight track = G280 + G140 = 16.44" (417.69 mm)
 Curved track = 3x R3 7.5° = 36.28" (921.54 mm)
 Package includes one curve R3 7.5°
 Compatible electric switch machine #35271

G-WRR3
35229

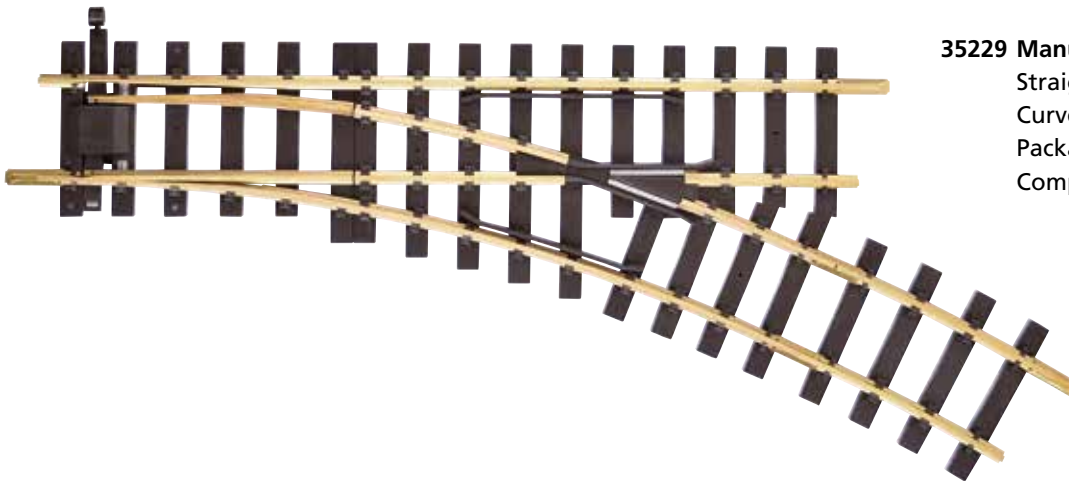

35229 Manual Switch, Right, R3, 22.5°
 Straight track = G280 + G140 = 16.44" (417.69 mm)
 Curved track = 3x R3 7.5° = 36.28" (921.54 mm)
 Package includes one curve R3 7.5°
 Compatible electric switch machine #35271

Larger Switches

G-WLR7

35226

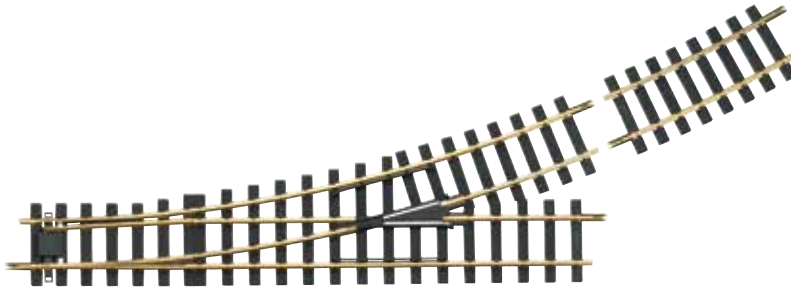

G-WRR7

35227

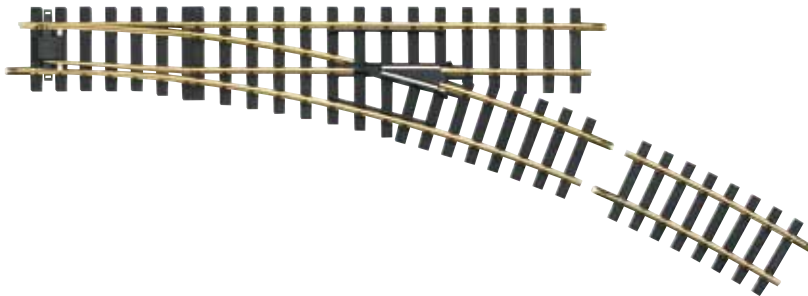

35226 Manual Switch, Left, R7, 22.5°

Curved track = 3 x Curve R7 7.5°, 61.60", 1564.62 mm

Straight track = G-600, 23.62", 600 mm

Package includes one Curve R7 7.5°

Compatible electric switch machine #35271

35227 Manual Switch, Right, R7, 22.5°

Curved track = 3 x Curve R7 7.5°, 61.60", 1564.62 mm

Straight track = G-600, 23.62", 600 mm

Package includes one Curve R7 7.5°

Compatible electric switch machine #35271

G-BWL

35224

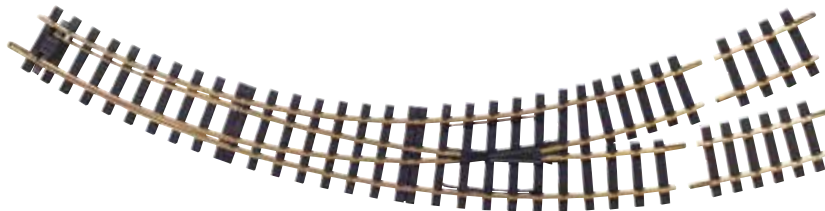

35224 Manual Curved Switch, Left R3-R5

Inner Curve = Curve R3, 52.5°

Radius 36.26", 921 mm

Outer Curve = Curve R5, 37.5°

Radius 47.24", 1200 mm

Package includes R3 7.5° and R5 7.5°

Compatible electric switch machine #35271

G-BWR

35225

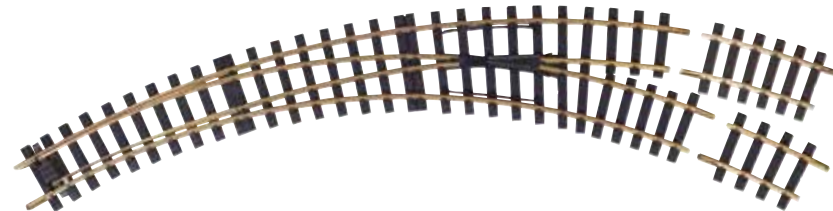

35225 Manual Curved Switch, Right R3-R5

Inner Curve = Curve R3, 52.5°

Radius 36.26", 921 mm

Outer Curve = Curve R5, 37.5°

Radius 47.24", 1200 mm

Package includes R3 7.5° and R5 7.5°

Compatible electric switch machine #35271

Flexible Track



G-SB320

35230 Tie Strip, 12.66"

Tie strip for construction of flexible track. Matches to a rail length of 12.66" mm (321,54). G-SB320 + G-SB280 make up the module length of 23.62" (600 mm)



G-SB280

35231 Tie Strip, 10.96"

Tie strip for construction of flexible track. Matches to a rail length of 280 mm (10.96"). G-SB280 + G-SB320 make up the module length of 23.62" (600 mm)



G-P3000

35250 Rail Section, 118.11"

Rail section for construction of flexible track. Use 2 x 35250 together with 5 x G-SB280, 5 x G-SB320, 18 pcs. of metal tie joiners from #35291 and 2 pcs. of metal rail joiners from #35290 to make approximately 118" (3 m) of track.



G-P1500

35251 Rail Section, 59"

Rail section for construction of flexible track. Use 2 x 35251 together with 3 x G-SB280, 2 x G-SB320, 8 pcs. of metal tie joiners from #35291 and 2 pcs. of metal rail joiners from #35290 to make approximately 59" (1.5 m) of track.



35285 Track Clips, 14 Pieces

Use to secure track sections together on temporary layouts.



35290 Metal Rail Joiners, 20 Pieces

Sturdy brass material to securely join rails. For replacement or for use with flexible track.



35291 Metal Tie Joiners, 20 Pieces

Sturdy brass clips to join flexible tie sections.

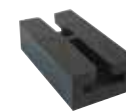

35292 Insulated Rail Joiners, 6 Pieces

Insulated joiners made of ultra-violet- and weather-resistant plastic.

35293 Rail Clamp On-Rail, 10 pieces

This clamp is designed to fit directly on the rails for the best connection. Fits PIKO and most other Code 332 rails.



35294 Rail Clamp Over-Joiner, 10 pieces

This clamp fits over the existing rail joiner, to allow easy installation on an existing layout, or to avoid removing existing rail joiners. Fit over PIKO and most other rail joiners. Check fit on other brands before tightening.





35280 Bumper
Typical railroad end-of-track bumper. Secures easily to track.

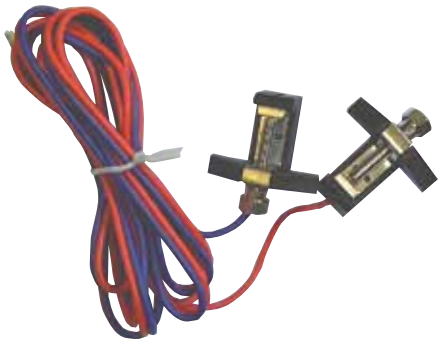

35270 Power Clamp, 1 Pair
With heavy-duty cable. Use for track power connection.

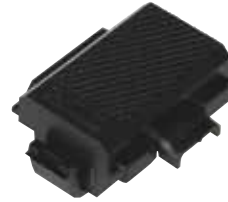

35268 Track Magnet
For triggering Reed Switch contacts, such as #35267 to activate locomotive bell and whistle/horn sounds.



35269 Loco Magnet
For triggering track contact #35272, adhesive-backed, 58 x 24 x 3 mm

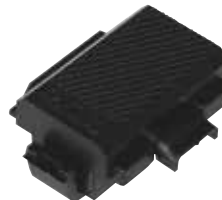

35272 Track Contact
Single-pole double-throw momentary reed-switch contact for controlling switches, signals and other accessories, triggered by the loco magnet # 35269

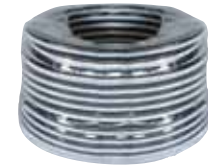

35400 Black/White Cable 25 m
Cross-section 1,5 mm², UL2468 16AWG



35401 Blue/Red Cable 25 m
Cross-section 1,5 mm², UL2468 16AWG



35402 Orange/White Cable 25 m
Cross-section 1,5 mm², UL2468 16AWG



35265 Relay Contacts DPDT

These double-pole double-throw relay contacts mount to the PIKO #35271 Switch Machine and can be used for many automatic control functions.



35266 Switch lantern, lighted

Lighted lantern mounts to PIKO #35271 Switch Machine and changes to indicate setting of switch points.



35271 Electric Switch Machine

Water-proof electric switch machine for all PIKO switches. Also fits LGB* and can be adapted to some other brands.

Contents:

- 1 x Front end 113 x 416 mm
- 1 x Rear end 113 x 402 mm
- 1 x End part 113 x 27 mm

35281 Rerailer / Grade Crossing with American and German Crossing Signs



Contents:

- 2 x Side Ramp Pieces
- 1 x Center Rerailer Piece
- 1 x 35200 Track G320
- 2 x US Railroad Crossbucks
- 2 x German Railroad Crossing Signs

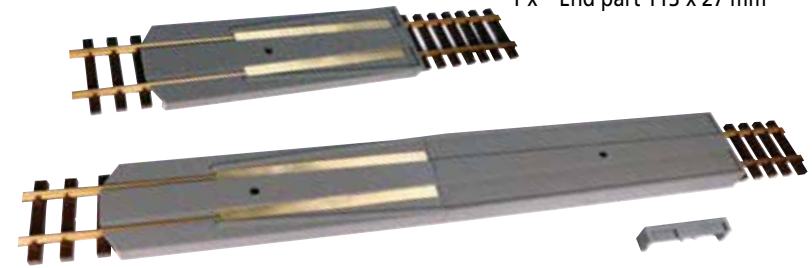

35282 Powered Rerailer

Our powered rerailer makes it easy to put any locomotive on the track. With large multi-wheeled locos, it can be a real challenge to get all the wheels correctly on the rails. And while a garden railway can be great fun, bending down in the rocks and dirt to put trains on the tracks is not fun. That struggle is now a thing of the past! Set the rerailer down on a powered track and the built-in contacts automatically pick up power from the rails. Just place a loco down on the rerailer - no need to fuss with accurately aligning wheels - and it rolls down onto the track under its own power. The PIKO powered rerailer features a short version for smaller locos, plus a snap-on extension for those really long locos. And it works just as well for freight and passenger cars of any size.



ca. 322 x 155 x 130 mm
12.7 x 6.1 x 5.1 "
Track length = G-320 12.6" (320 mm)

* LGB is a trademark of Gebr. Märklin & Cie, GmbH

TRACK SETS – EXPAND YOUR RAILROAD EMPIRE

The PIKO G-Track sets allow beginners as well as experienced modellers to build up a basic stock of track elements at a reasonable price, when starting with the PIKO G-track system. The uncomplicated, clear design of the PIKO G-Track system makes it possible to continuously extend existing layouts by adding further sets. The sets

contain the color coded pieces shown in the graphics below. The white sections are the typical starter set circle. The color coding conforms to the PIKO G-Track color coding system. The switches contained in the Track Sets can be converted to electric operation at any time by installing an electric switch machine.

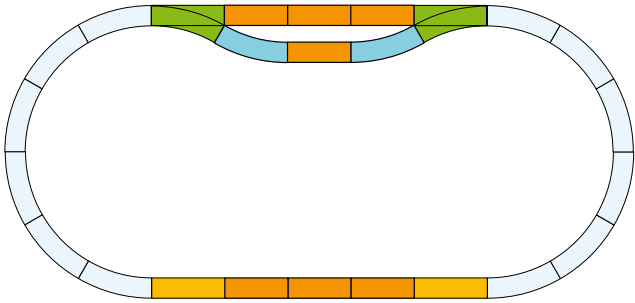

35300 Station Track Set

- 1 x 35220 WLR1 (Switch left)
- 1 x 35221 WRR1 (Switch right)
- 2 x 35211 R1 (Curved track R1 23.62")
- 2 x 35200 G320 (Straight track 12.60")
- 7 x 35201 G280 (Straight track 11.02")
- Floor area: 9.19' x 4.26'
- Minimum area for assembly: 9.84' x 4.92'

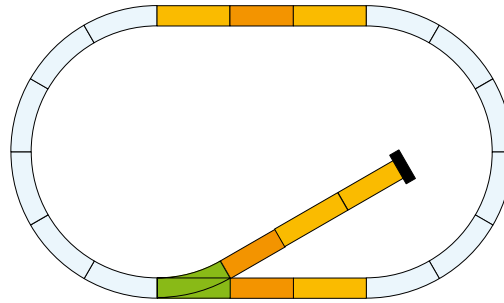

35301 Siding Track Set

- 1 x 35280 Buffer Stop
- 1 x 35220 WLR1 (Switch left)
- 5 x 35200 G320 (Straight track 12.60")
- 3 x 35201 G280 (Straight track 11.02")
- Floor area: 7.38' x 4.26'
- Minimum area for assembly: 8.04' x 4.92'

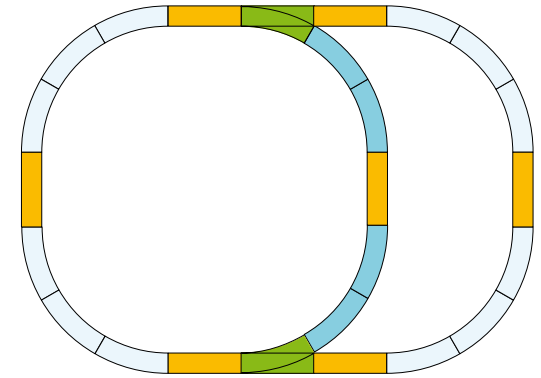

35302 Double Oval Track Set

- 1 x 35220 WLR1 (Switch left)
- 1 x 35221 WRR1 (Switch right)
- 4 x 35211 R1 (Curved track R1 23.62")
- 7 x 35200 G320 (Straight track 12.60")
- Floor area: 7.55' x 5.25'
- Minimum area for assembly: 8.20' x 5.91'



35310 Track and Power Set

- 12 x 35211 R1 (Curved Track R1 23.62")
- 14 x Track Clips
- 1 x Power Clamp w/Wires
- 1 x Analog Throttle, Basic
- 1 x Safety Approved 120 V Transformer
24 V / 45 VA
- Floor area: 4.26' x 4.26'
- Minimum area for assembly: 4.92' x 4.92'



Using PIKO G-Track in conjunction with LGB** track

PIKO G-Track Code 332 brass rail and rail joiners are fully compatible with LGB track. PIKO G-Track sections can be easily integrated into existing LGB** track layouts. The following charts show how the track sections compare to each other.

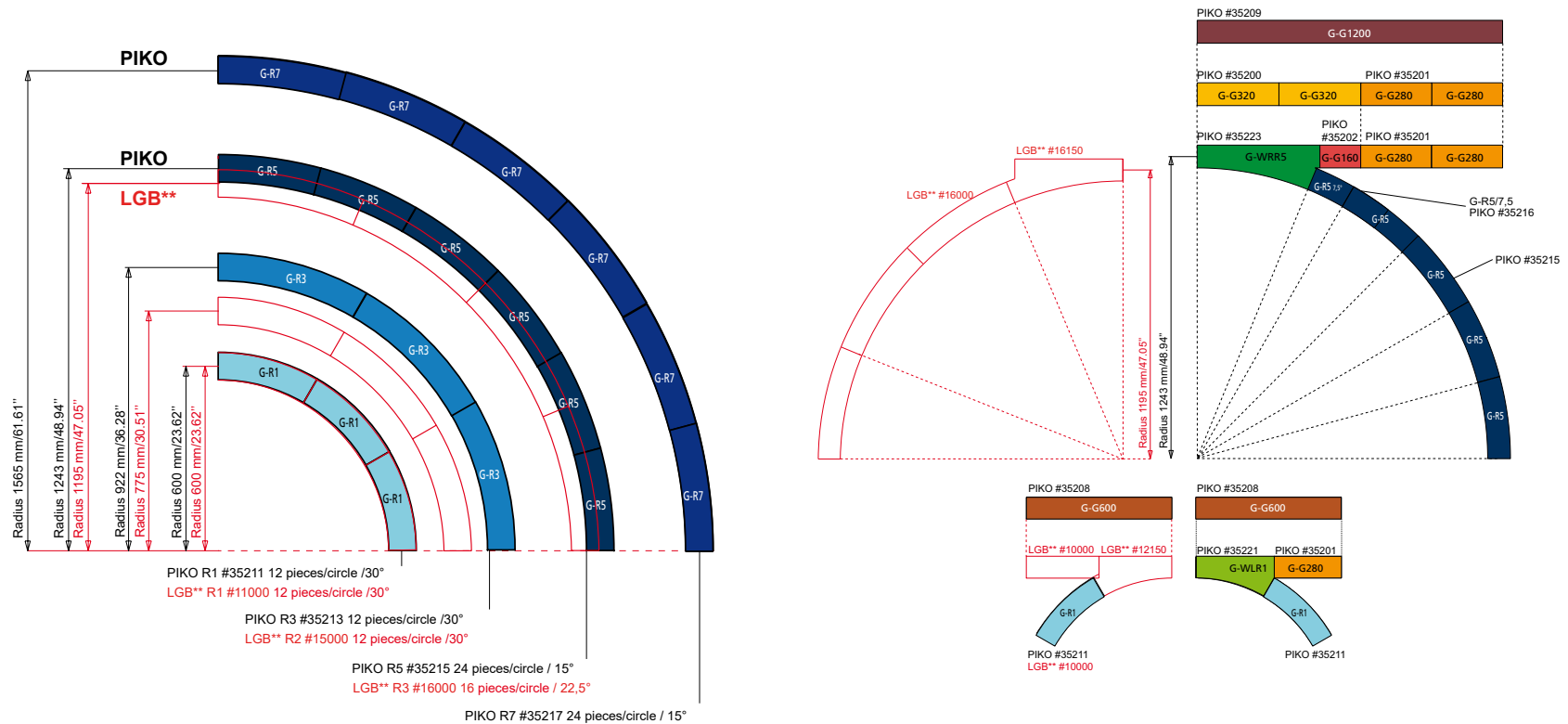

| | |
|---|-------|
| PIKO #35209 1200 mm / 47.24" | PIKO |
| G-G1200 | |
| LGB** #10610 1200 mm / 47.24" | LGB** |
| PIKO #35208 600 mm / 23.62" | PIKO |
| G-G600 | |
| LGB** #10600 600 mm / 23.62" | LGB** |
| PIKO #35200 320 mm / 12.66" PIKO #35201 280 mm / 10.96" | PIKO |
| G-G320 G-G280 G-G320 G-G280 | |
| LGB** #10000 300 mm / 11.81" | LGB** |
| PIKO #35202 160 mm / 6.33" PIKO #35203 140 mm / 5.48" | PIKO |
| G-G160 G-G140 G-G160 G-G140 G-G160 G-G140 | |
| LGB** #10150 150 mm / 5.91" | LGB** |

** LGB is a trademark of Gebr. Märklin & Cie. GmbH



LOCOMOTIVES

- > Powerful five-pole precision can-type motor
- > Exceptional pulling power
 - > Concealed electrical pickups on driving wheels
 - > Spring-loaded sliding pickup shoes
 - > Precise paint schemes and lettering



See this and more great locomotives on the following pages.



The PIKO Clean Machine With the "Clean Machine" version of the GE 25-Ton diesel, PIKO brings you a completely different concept in track cleaning. Common household rechargeable batteries provide extensive running time. Track cleaning operation is simple - just let it run around the layout till even heavily oxidized track is polished clean. Once the Clean Machine has cleared the way, track-powered locos can run smoothly! The Clean Machine is exclusively powered by 6 'AAA' batteries (not included - high-capacity rechargeable cells are recommended), which provide up to two hours of running time for cleaning even large layouts. The front "radiator panel" of the engine hood opens for easy access to the quick-change battery clip.

> track cleaning function
> completely battery-powered

38506 Clean Machine R/C operation, completely battery-powered

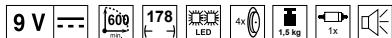

Clean Machine R/C For even more fun and convenience, we suggest the Clean Machine R/C. The included pocket remote gives easy walk-around radio control of the loco's speed, direction and an emergency stop function. 8 easily selectable R/C channels allow operation of multiple locos independently. Or, two or more locos can be set to the same R/C channel and run together from one remote, for even faster track cleaning.



38508 Clean Machine Green (non-R/C), completely battery-powered



The economical Clean Machine Green offers incredibly simple operation. Select 'Forward' or 'Reverse' with the switch under the cab and let it roll. The switch also includes a center 'Off' position to park the loco when not in use.



35416 Track Cleaning Shoes, Clean Machine, 2 sets

Package of 4 cleaning shoes with very long-lasting, highly-effective mesh cleaning pads. Clever snap-on / snap-off installation makes changing cleaning shoes quick and easy, with no tools or disassembly required.

25-TON DIESEL LOCOS WITH DIGITAL SOUND

All 25-Ton Diesels on this page include:

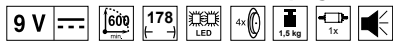

Another industry first from PIKO! 25-Ton diesel locos factory-equipped for full battery-powered operation, with PIKO R/C and realistic TCS digital sound built-in. Run the train over any track - clean, dirty or unpowered, even across the floor! It's all controlled from the convenient Pocket Remote, included with the loco. Six standard size 'AAA' batteries (not included, high-capacity rechargeables are recommended) allow for long running time. The quick-change battery clip is located inside the engine hood and the front panel snaps off for easy access. 8 selectable R/C channels allow running multiple locos independently, or controlling multiple locos together in one train consist. What could be more fun than one PIKO 25-Tonner? A double-header, triple-header, or more! In addition to the bright directional LED constant lights and cab interior light, the highly realistic digital sound is completely new, a joint development of PIKO and TCS, a name already well-respected for digital sound decoder technology. Numerous authentic sounds function automatically. And if the powerful high-fidelity sound becomes a bit much, there's an easily-reached volume control in the loco cab. Press a button to turn on the bell as the train pulls out of a station. Press again to turn it off. Press and hold another button to blow the horn as long as desired. Give the correct two blasts when starting in forward, and three in reverse, or a few quick warnings to clear the tracks. Even blow the grade crossing pattern of two longs, a short and a long blast. And this realistic control is easy with just one hand, at up to 80' range - unaffected by daylight and big enough for the great outdoors.



38509 SF 25-Ton Diesel, Battery R/C w/Sound

NEW 2022



38510 PRR 25-Ton Diesel, Battery R/C w/Sound



NEW 2022



38511 US Army 25-Ton Diesel, Battery R/C w/Sound

Pre-Production Image:
Actual Item Subject to Change



NEW 2022



38512 KLV Thumper 25-Ton Diesel, Battery R/C w/Sound





38229 NYC Mogul Loco 6803 with Sound and Smoke





For a colorful consist pair this loco with 38652 NYC Wood Combine and the 38650 and 38651 Wood Coaches as seen in this image.



The steam loco on this page includes:

- › Bright, Directional LED Lights and 5-Volt Smoke System
- › High-Volume 3-Watt Digital Steam Sound System, with:
 - Synchronized Steam Exhaust Chuff
 - Correct Bell and Whistle Signals
 - Dynamo, Blower, Air Pump and Steam Release
 - Brake Squeal and Brake Release
 - Coal Shoveling (on coal-fired locos)
- › Built-in 'dual-mode' decoder for full-feature operation on either Analog DC or Digital DCC



38231 PRR Mogul with Sound and Smoke

**NEW
2022**



38233 SF Mogul Loco with Sound and Smoke

The sound-equipped steam locos on these two pages include:

- › Bright, Directional LED Lights and 5-Volt Smoke System
- › High-Volume 3-Watt Digital Steam Sound System, with:
 - Synchronized Steam Exhaust Chuff
 - Correct Bell and Whistle Signals
 - Dynamo, Blower, Air Pump and Steam Release
 - Brake Squeal and Brake Release
 - Coal Shoveling (on coal-fired locos)
- › Built-in 'dual-mode' decoder for full-feature operation on either Analog DC or Digital DCC

Celebrating the elaborate adornments on locomotives of the late 1800s, The Union Pacific and Santa Fe Moguls on these two pages feature completely original Western art paintings by a talented artist, commissioned exclusively for PIKO and reproduced in beautiful full color on the tender sides as only PIKO can do.



38232 UP Mogul 1201 with Smoke & Digital Sound



38234 D&RGW Mogul Loco with Sound and Smoke

NEW
2022

Prototype

In their quest to reduce fuel cost while increasing tractive effort for new steam locomotives, North American designers developed a new wide smoke box design that allowed the use of anthracite waste as a cheap fuel source. Introduced during the second half of the 19th century the new smoke box was so wide that it would have blocked the view of the engineer. Thus the engineer's cab had to be moved atop and astride the boiler. Only the fireman remained in his usual spot between firebox and tender. To this day the "Camelback" design is also known under the somewhat peculiar name Mother Hubbard in the US.

Model

The PIKO Camelback models were designed based off of Reading 1396, an 0-6-0 "Camelback", representing a late "Camelback" design with a straight tender and roof for the fireman. "Camelbacks" like it were built up until 1927 when construction of new "Camelbacks" was banned for safety reasons.

This sound-equipped Camelback steam loco includes:

- › Bright, Directional LED Lights and 5-Volt Smoke System
- › High-Volume 3-Watt Digital Steam Sound System, with:
 - Synchronized Steam Exhaust Chuff
 - Correct Bell and Whistle Signals
 - Dynamo, Blower, Air Pump and Steam Release
 - Brake Squeal and Brake Release
 - Coal Shoveling (on coal-fired locos)
- › Built-in 'dual-mode' decoder for full-feature operation on either Analog DC or Digital DCC



38242 PRR Camelback 2-6-0 Loco 628 with Sound and Smoke





38209 D&RGW Mini-Mogul

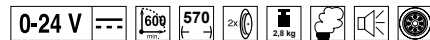

38250 PRR 2-6-0T Saddle Tank Loco with Smoke & Analog Sound

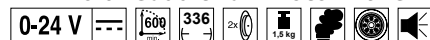

Powerful, reliable, economical locos for your railroad:

- › The locos on these two pages include well-proven and smooth-running PIKO gear drives with precision can-type motors and 8-point electrical pickup. All include directional "golden glow" LED headlights and nicely detailed valve gear.
- › 38209 is ready for installation of a 36221 Analog Steam Sound Kit, as well as a 36142 5-Volt Smoke Unit and 36143 5-Volt Regulator. Alternatively, the 36220 Digital Steam Sound Kit can be adapted.
- › Plastic tender wheels can be easily replaced with 2 packs of 36164 Metal Wheelsets if desired
- › 38250 features a 5-Volt Smoke System and Analog Steam Sound.
- › To activate bells and whistles, place 35268 Track Magnets at desired locations around the layout.



37210 DB III Steam loco BR 64 with switchable chassis lighting and smoke



All BR 24 / BR 64 locos include:

- › Finely detailed superstructure
- › Numerous separately applied railings and pipes
- › Openable smokebox door
- › Clear view through detailed cab interior
- › Detailed spoked wheel centers with stainless steel tires
- › 7-pole ball-bearing Bühler motor
- › Complete and detailed valve gear
- › Switchable 5-volt smoke generator
- › Directional LED lighting
- › Engineer figure
- › Prepared for the installation of the PSD XP 5.1 S #36522. The requirement is that the locomotive is equipped with the Connector 36510.



37212 OeBB III BR 64 Steam loco with switchable chassis lighting and smoke



Prototype

The BR 24 shares its basic design with the BR 64. Just like its sisters BR 24 was considered reliable, strong and versatile. Since entering service in 1928 the BR 24 proved itself as a light and nimble passenger service locomotive. Its larger coal and water capacity meant that it could be used on long branch lines or even hauling fast trains. The railroaders in the former East Prussia nicknamed the locomotive "Steppe Horse." Hauling passenger, freight, and mixed trains, the successful, 900hp rated standard design always performed reliably. The DB retired the last BR 24 in 1966, while some Steppe Horses operated in Poland until the mid-seventies.

Model

The PIKO model of the Deutsche Reichsbahn's BR 24 impresses with its fine detailing and versatility. Just like in real life, the Steppe Horse can be used with a variety of cars. The compact, sturdy locomotive features a steam generator with separate on/off switch. The precisely manufactured wheel sets with stainless steel rims ensure a very reliable power pickup from the track. The PIKO BR 24 model is equipped with a smoke unit and directional lighting, and is also ready for easy installation of a digital decoder and sound. An engineer figure completes the cab.

Suitable Accessories:

#36510 Connector PCB for PSD XP 5.1

#36500 PSD XP 5.1

#36522 PSD XP 5.1 S BR 24



37222 DR III BR 24 Steam Loco, Wagner Smoke Deflectors with Smoke





37240 DR IV BR 50 Reko Steam Loco with Smoke



Prototype

The class 50, built from 1939 onwards, is one of the most frequently built German freight locomotives and was for a long time after the war one of the most important supports in freight traffic in East and West Germany. In other countries, too, locomotives of this class were used, in some cases until the end of the steam locomotive era. The light and comparatively fast locomotives were used as universal locomotives in the course of time before almost all types of trains. The 50s even mastered individual express and D trains with excellence.



37244 DRG II BR 50 Steam Loco

Ready for easy installation of cab light, digital decoder and sound.



37245 DRG II BR 50 Steam Loco w/Smoke and Sound, w/digital Vanishing Coal effect

Factory-equipped with decoder, smoke and sound on DC or DCC, plus "disappearing coal load" feature on DCC, the 37245 offers a wide range of sound functions on Analog DC as well as Digital DCC.



All Steam Locos on these pages include:



Model

The lovingly implemented model in the respective harmonious design has a finely detailed overall appearance corresponding to the model and can be used in many ways due to its excellent driving characteristics. Many applied details, e.g. wind deflectors, sand pipes and the applied number plate on the smoke chamber door underline the noble character of the locomotive. The model has fine replicas of the handlebars and filigree spoke wheels with stainless steel tires as well as a light change white/white. The analogue version is of course prepared for upgrading a digital system and sound. The heavy PIKO model has two traction tires. The plastic parts are made of a special material for a long-lasting outdoor garden. The features of the driver's cab lighting, the smoke set and the flickering light in the fire box are switchable by means of a function key (with the digital version) or a switch (analogue).

Suitable Accessories:

#36510 Connector PCB for PSD XP 5.1

#36500 PSD XP 5.1



#36530 PSD XP 5.1 S BR 24



37242 DB IV BR 050 Steam Loco with Smoke

Ready for easy installation of cab light, digital decoder and sound.



37243 DB IV BR 050 Steam Loco with sound and smoke

Factory-equipped with decoder, smoke and sound on DC or DCC, plus "disappearing coal load" feature on DCC, the 37243 offers a wide range of sound functions on Analog DC as well as Digital DCC.



Prototype

The tank locomotive of the class 95 started service as class T20 in early 1923. It was able to pull 2060 tons at 31mph on flat terrain. After the Second World War, 14 of the 45 machines were used by the German Federal Railways. Their operation included helper service on grades. The last locomotive was retired in 1958 from service by the Federal Railways. After the war, the Deutsche Reichsbahn received 31 locomotives of the BR 95 class. To increase capacity in the early 1970s, the tonnage per train was raised for the BR 95. Several locomotives are preserved in museums. Engine 95 027 is operational and can be seen in service from time to time today.

Model

The PIKO model of the BR 95 shows all the relevant details of the prototype, down to the finest paint and print features. It excites with a prototypical, but yet finely detailed appearance and versatile use. The machine also impresses with its robustness, precisely manufactured wheels with stainless steel tires, and a very reliable power pick-up. The 37232 model is factory-equipped, not only with a smoke unit, but also with a digital decoder and sound, offering many sound functions on analog DC operation as well as digital DCC operation.



☒ 37231 DR IV-V BR 95 Steam Loco with sound and smoke

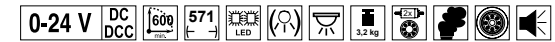

MODEL VARIATION
2022



Prototype: Juergen Klugert

37232 DR IV BR 95 Steam Loco, New construction boiler oil with Sound



Prototype

As early as 1905, powerful T 16 Class 0-10-0s were in service on the Prussian State Railroads. Increasing tonnage and the desire to use the T 16s in a larger operating area led to the development of the T 16.1 Class. The first T 16.1s, later classified as the BR 94.5s, were delivered in 1913. From the beginning they were used in heavy switching service and on steeply-graded routes. The T 16.1 was even able to replace rack locomotives on some steep grades. Following two world wars, T 16.1s were scattered across Europe and found themselves working for various national railroad administrations. The Deutsche Reichsbahn retired their T 16.1 fleet in 1971, while the Deutsche Bundesbahn kept theirs in service for another three years. Today there are several T 16.1s existing as museum locomotives, with a noteworthy collection of four examples owned by the Rennsteigbahn Steam Train Association.

Model

PIKO now makes it possible to have a model of the famous "Rennsteighirsch" train in your own backyard! Our new BR 94.5 steam locomotive is a most welcome addition to G scale. The model is a fine example of prototype fidelity married to robust design, which guarantees plenty of play value. The durable locomotive is tough enough for the challenges of extended outdoor operation and at the same time is highlighted by sophisticated features like a glowing red firebox and a factory-installed smoke unit. The BR 94.5's articulated chassis allows it to operate over small radii and it's innovative axle bearings keep it's electrical wipers in good contact with the rails.



Prototype Photo: Gideon Grimmel

37250 DR IV BR 94 Steam Loco



37251 DR IV BR 94 Steam Loco with Sound

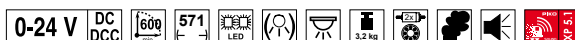

All BR 95 / BR 94 locos have:

- › Finely detailed superstructure
- › Numerous separately applied railings and pipes
- › Openable smokebox door
- › Clear view through detailed cab interior
- › Detailed spoked wheel centers with stainless steel tires
- › 7-pole ball-bearing Bühler motor
- › Complete and detailed valve gear
- › Switchable 5-volt smoke generator
- › Directional LED lighting
- › Engineer figure
- › 37250 is prepared for installation of a 36500 decoder and 36521 sound kit.



37202 DB III BR 80 Steam Loco



Winter can be a time for snow and shop crews had to be resourceful to keep equipment running on time. Many crews found that they could add a snow plow to older tenders they had sitting around to assist in clearing snow from the tracks. By filling the tender with water to make it heavy, they could place it in front of a loco and push snow drifts away from the mainline to keep their freight and passenger service running.



37821 DR IV Snow Plow







Photo: Thomas Stegner

> Now available in G scale: the observation car class 491 glass train of the Deutsche Bundesbahn

Model

With our glass train, PIKO has brought another piece of railroad history to G scale. The glass car body allows for a full view of the detailed interior, which includes factory-installed figures and interior lighting.

The engineer's control stand is also illuminated. The headlights and taillights change from red to white with the direction of travel. For operation in Austria, an SBS 65 single-arm pantograph was installed on the prototype in 1976. The Era IV model includes this feature. Other roof equipment like cables and insulators are faithfully reproduced. A powerful Bühler motor provides the "glass train" with plenty of heft, and two additional pick-up shoes have been added to ensure a constant power supply. The digital version of the ET 91 is factory-equipped with a sound decoder and features a digitally-controlled pantograph. The analog version can be converted to digital and sound operation.

Prototype

In 1935, for the 100th anniversary of the German railways, the Fuchs Railcar Works of Heidelberg was commissioned to manufacture 2 self-propelled observation cars for the purpose of sight-seeing trips. The German Reichsbahn classified these cars as ET 91. The sophisticated railcars were designed to provide passengers with a panoramic view, so as many surfaces as possible were comprised of glass including parts of the roof. Their appearance earned them the nicknames "glass train" or "rolling glass box" or "the glass one." The Reichsbahn hoped the new railcars would win back passengers from bus travel, so fares for the new cars were advertised as 33% lower compared to third class fares.

The total length of the railcars was approximately 20 m (65 ft.). They originally had a top speed of 120 km/h (75mph). This was later reduced to 110 km/h (68mph). One car could accommodate a maximum of 72 people.

One railcar was completely destroyed during the war. The other was repainted and returned to service by the German Federal Railroad. The original color scheme was probably light blue, and later changed to dark blue. In 1953 the ET 91 became the BR 491 and the car was given a red/ivory paint scheme. In 1971 it was painted Olympic Blue for the Olympic Games. The car last wore a dark blue paint scheme. The story of the remaining "glass train" ended tragically during a panoramic trip in 1995, when it was totaled in an accident at Garmisch-Partenkirchen. After 60 years of operation, one of DB's oldest pieces of rolling stock was retired permanently.



37330 DB IV Glass Train



37331 DB IV Glass Train, Sound

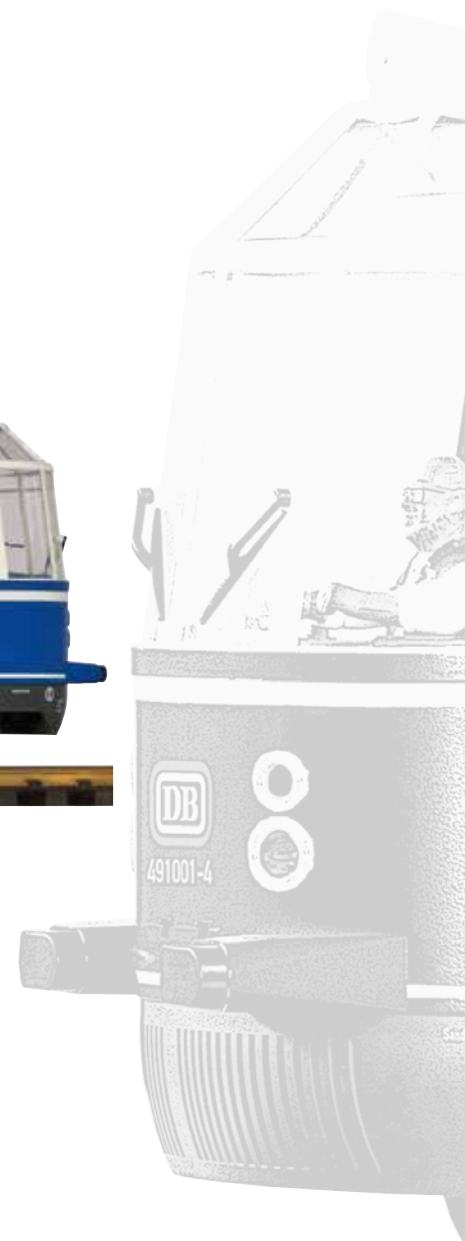

All BR 103 include:

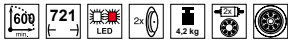

Suitable Accessories:

#36510 Connector PCB for PSD XP 5.1

#36500 PSD XP 5.1



Prototype

For many years, the six-axle class 103 electric locomotives were regarded by the Deutsche Bundesbahn as the flagship in heavy passenger train traffic and represent one of the most popular German locomotive series. The DB used four pre-series models as high-speed locomotives from 1965, and by 1974 a total of 145 additional series locomotives were in operation. With a continuous output of 7,440 kW (10,116 hp), the 103s are still among the most powerful one-piece locomotives. The first series locomotives were delivered with scissor pantographs, from 1976 onwards SBS65 single-arm pantographs were used. In addition, the locomotives lost their front skirts and received buffers without cladding. With their elegant and timeless design, the noble racers shaped the high-quality travel traffic for many years and became cult objects already during their regular service. From 1997 onwards, the 103s were gradually phased out until 2003 and replaced by the new 101 series. Several locomotives are preserved in museums.



37441 DB IV BR 103 Orient Red w/Bib and Single-Arm Pantograph



37440 DB IV BR 103 Electric Loco



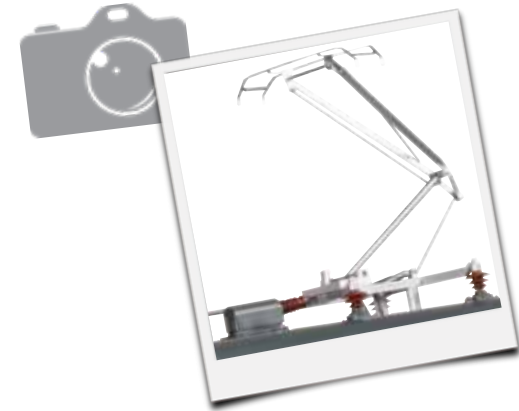

37442 RailAdventure VI BR103 Electric Loco, Sound

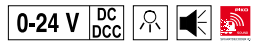

NEW
2022

37443 DB IV BR 103 Electric Lufthansa, Sound

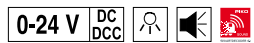

Suitable Accessories:

#36511 Connector PCB for PSD XP 5.1

#36500 PSD XP 5.1



37436 DB III E 94 Electric

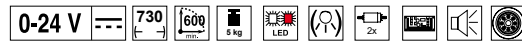

The German BR 194 was built by AEG starting in 1940. The 128t six-axle electric locomotive was designed for freight service but was used in passenger and express train service as well. By the end of WWII a total of 146 locomotives were delivered to the then DRG. Between 1954 and 1956 the DB ordered a further two batches of locomotives numbered E 94 178 – E 94 196 and E 94 262 – E 94 285 to alleviate a shortage of powerful freight locomotives. For the same reason a further four used BR 194s were purchased from the Eastern German DR. The PIKO model shows a high level of detail. The fan louvers, rows of rivets, grab irons, and metal pantograph are all meticulously reproduced, yet robust enough for garden railroading. Two gearboxes with ball bearing equipped motors ensure excellent pulling performance.



37432 Electric Loco BR 254 "Crocodile" DR IV





37429 Flixtrain VI Taurus Electric



37400 ÖBB VI RH 1116 Taurus Electric Railjet, Sound



All Taurus Locos include:



Suitable Accessories:

#36511 Connector PCB for PSD XP 5.1

#36500 PSD XP 5.1



The PIKO model of the Taurus electric loco is striking, and extremely so in the bright green livery of FlixMobility GmbH, in service since March 2018. With several of the #37664 passenger coaches trailing behind, you can recreate this recent addition to the growing list of private train service providers in Germany.

The Austrian Federal Railways Railjet service started in 2008. It uses modern and powerful Rh 1116 "Taurus" electric locomotives and conventional passenger cars, as opposed to other modern articulated trains like the ICE3. The attractive maroon, red and gray Railjet paint scheme is a popular sight in and around many cities, such as Vienna, Salzburg and Munich. The PIKO model of the Railjet Taurus loco comes factory-equipped with a DCC decoder and authentic digital sounds of the real loco.

For matching Railjet passenger coaches, see page 76

**NEW
2022**



37571 DR IV BR 118 Diesel 6-Axle, Sound

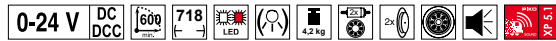

37576 DR III BR V180 Diesel, 4-Axle, Sound



**NEW
2022**



37512 DB V BR 218 Diesel w/Bib, Sound

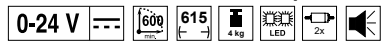

Prototype

In 1970, as part of the transition from steam to diesel traction, the DR imported BR 130 diesel-electric locomotives from Lugansk in the Soviet Union. Following the successful introduction of the BR 130, the DR received a freight variant classified the BR 131 with a reduced top speed of 100 km/h (62 mph) for higher tractive effort. The BR 131 soon became an iconic "mountain engine." The 76 locomotives supplied to the DR shaped the image of freight train service in the Thuringian Forest and was also found in the Harz foothills and the Ore Mountains. Along with the BR 131, the BR 132 six-axle diesel locomotive was based on the class 130 series. The BR 132 was designed as a universal express and freight locomotive for mainlines and important branchlines. They featured modern electric train heating and a top speed of 120 km/h (74mph). These robust and reliable engines have served admirably in their roles and are now classified by DB AG as the BR 232. They form the basis for new versions of the "Ludmilla" like the BR 232.9, BR 233, BR 234, and BR 241.

Model

PIKO's attractive Garden Scale models of the BR 130/131/132 family of diesel locomotives fulfill the wishes of numerous G-scalers around the world who love these big diesel locomotives. The PIKO Ludmillas feature sturdy trucks, separately-applied handrails, and all the external details of their respective 1:1 prototypes. Internally, the models feature detailed engine rooms and cab interiors with engineer figures. Lighting features include directional headlights and taillights that change over depending on the direction of travel, and digitally-activated high beams. Engine room lighting can be added if desired. The impressive BR 130/131/132 from PIKO boast a high tractive force and exceptional running characteristics thanks in part to their chrome-plated wheelsets that ride on ball bearings. Each locomotive is factory-equipped with digital sound so you can bring the typical sounds of the "Ludmilla" to your G scale layout.

Suitable Accessories:

#36510 Connector PCB for PSD XP 5.1

#36500 PSD XP 5.1



**NEW
2022**

37583 DR IV BR 132 Diesel with Sound



Suitable Accessories:

#36510 Connector PCB for PSD XP 5.1

#36500 PSD XP 5.1

#36533 PSD XP 5.1 S BR 106



Prototype

As early as 1953, the Deutsche Reichsbahn had plans drawn up for a new diesel loco to replace old worn-out locomotives in switching service. LKM Babelsberg led the development, which produced two prototype locos in 1958. Series production began in 1962. Some operating experience led to design improvements. The V60.12 series, known from 1970 on as the BR 106 class, provided a new engineer's cab with enhanced protection from the elements for the crew. The locos went on to prove themselves quite well in decades of service on the DR. Some are still used today in railway construction and industrial service.

Model

With the model of the BR106, PIKO brings to market another classic of the DR, and another model requested by many fans. The PIKO BR106 faithfully reproduces the looks of the real thing. And the robust construction features hard chrome-plated wheels with ball-bearings on the geared axles, directional LED lights and an engineer figure in the cab. The appearance is further enhanced with many individual details, such as handrails, windshield wipers, and the fascinating siderods and eccentric crank of the drive mechanism. The non-sound version is ready for easy installation of a digital decoder and sound unit. The sound version is factory-equipped with a digital decoder and sound system for an extra touch of realism.



37590 DR IV BR 106 Diesel (non sound)



37591 DR IV BR 106 Diesel with sound



All V 60 / BR 346 on this page include:

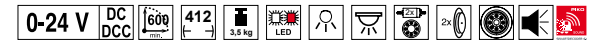

37592 DR III BR V60 Diesel, Sound



37593 Press VI BR 346 Diesel, Sound

All BR 236 / V20 include:

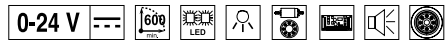

Suitable Accessories:

#36510 Connector PCB for PSD XP 5.1

#36500 PSD XP 5.1

#36539 PSD XP 5.1 S BR 260



37550 DB III V20 Diesel Switcher



Model

The PIKO V20, the little sister to the 3-axle V 36, is another very versatile locomotive choice for the garden-rail-roading enthusiast. The locomotive can be used as switcher or as road engine pulling short passenger or freight trains. Both axles of the small and nimble PIKO locomotive are driven. The jackshaft with its rotating counter weight between the axles is a special eye-catcher. Just like the PIKO V36 before, the PIKO V20 correctly reproduces the many louvers and vents that are typical for the prototype. The model features separately applied grab irons. It is equipped with white directional lighting, prepared for DCC conversion and can be fitted with diesel sound.



37532 DB III Diesel Locomotive BR 236, with Cupola



All BR 100 / 199 / 204 include:

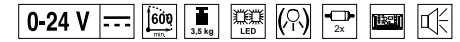

☒ 37560 Diesel Loco BR 204 DB AG V



Suitable Accessories:

#36510 Connector PCB for PSD XP 5.1

#36500 PSD XP 5.1

#36539 PSD XP 5.1 S BR 260



37568 DR IV BR 110 Diesel Wine Red



37543 HSB V BR 199 Harzkamel



37526 DB IV BR 260 Diesel



Suitable Accessories:

#36510 Connector PCB for PSD XP 5.1

#36500 PSD XP 5.1



VT 11.5 TEE Train

The streamlined diesel-powered VT 11.5 trainsets developed in the 1950s were the flagships of the Deutsche Bundesbahn. These brought increased comfort to the premier international Trans-Europe Express (TEE) service. The PIKO model brings this unique train to life in G-Scale. Both end-units are powered and the powered end units are equipped with hard-chrome plated wheels and ball bearings on driven axles. The trainset is equipped with directional head- and taillights as well as prototypical interiors. It can be fitted with sound, digital decoder and interior lights.



37320 DB III TEE Diesel VT11.5 3-Unit Train

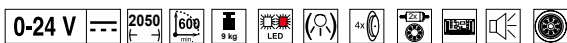



37308 DB III Railbus VT98

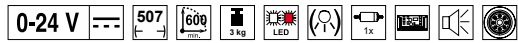

Suitable Accessories:

#36510 Connector PCB for PSD XP 5.1

#36500 PSD XP 5.1



37690 DB III VS98 Railbus Trailer-Only

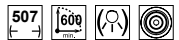

**NEW
2022**



37309 DB IV BR798 Railbus & Trailer, Mint Green, Sound





PASSENGER CARS

- > Precision engineering
- > Excellent running characteristics
 - > High level of detail and precise scale proportions
 - > Elaborate paint schemes
 - > Fine lettering



See this and more great passenger cars on the following pages.

Available for all American Passenger Cars:

© #36164

Suitable Accessories:

#36136 interior lighting is available for all Wood Drover's Caboosees

Interior Lighting Kit #36135 is available for all American-style wood coaches, combines, and baggage cars.



38600 D&RGW Wood Coach 331



38601 D&RGW Wood Combine 242



38735 D&RGW Sightseeing Car with Bench Seats



38602 D&RGW Wood Drover's Caboose 215 with Metal Wheelsets and Lighted Markers



38603 D&RGW Wood Baggage Car 126



38610 D&RGW Wood Coach 319





38231 PRR Mogul w/Sound and Smoke
(see page 40)

Suitable Accessories:

#36136 interior lighting is available for all Wood Drover's Caboosees
Interior Lighting Kit #36135 is available for all American-style wood coaches, combines, and baggage cars.



**NEW
2022**

38660 PRR Drovers Caboose 21015 with Metal Wheelsets and Lighted Markers

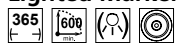

**NEW
2022**

38657 PRR Wood Coach 23117

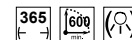

**NEW
2022**

38658 PRR Wood Coach 23119



**NEW
2022**

38659 PRR Wood Combine 22610

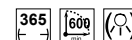

Suitable Accessories:

Interior Lighting Kit #36135 is available for all American-style wood coaches, combines, and baggage cars.



38652 NYC Wood Combine 215



38650 NYC Wood Coach 286



38651 NYC Wood Coach 287



38229 NYC Mogul Loco 6803 with Sound & Smoke
see page 38

Available for all American Passenger Cars:  #36164



38628 SF Wood Coach 16521



38233 SF Mogul Loco with Sound & Smoke
(see page 40)

Suitable Accessories:

#36136 interior lighting is available for all Wood Drover's Caboosees
Interior Lighting Kit #36135 is available for all American-style wood coaches, combines, and baggage cars.



38626 SF Wood Baggage Car 72493



38623 SF Wood Drover's Caboose 20871 with Metal Wheelsets and Lighted Markers

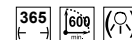

Available for all American Passenger Cars:  #36164

Suitable Accessories:

#36136 interior lighting is available for all Wood Drover's Caboosees
Interior Lighting Kit #36135 is available for all American-style wood coaches, combines, and baggage cars.



38753 WP&YR Sightseeing Car with Bench Seats



38634 WP&YR Wood Drover's Caboose 211 with Metal Wheelsets and Lighted Markers



 38633 WP&YR Wood Combine 209



38631 WP&YR Wood Coach 218





38232 UP Mogul 1201 w/Smoke & Digital Sound
(see page 41)



38653 UP Wood Coach 1873



38654 UP Wood Coach 1878



38655 UP Wood Coach 1922



38656 UP Wood Drovers Caboose 1953 with Metal Wheelsets and Lighted Markers



Available for all American Passenger Cars:  #36164

Suitable Accessories:

#36136 interior lighting is available for all Wood Drover's Caboosees
Interior Lighting Kit #36135 is available for all American-style wood coaches, combines, and baggage cars.



 38646 C&S Wood Drover's Caboose 99 with Metal Wheelsets and Lighted Markers



 38647 C&S Wood Combine 4



 38645 C&S Wood Combine 20



EUROPEAN PASSENGER CARS

Available for all Silver Coin Cars: #36165
 Interior Lighting for Silver Coin Coaches: #36132



37630 DB IV Silver Coin Coach ABnd, 1./2. cl.



37631 DB IV Silver Coin Coach Bnd, 2. cl.



**NEW
2022**

**NEW
2022**



37632 DB V 2. Cl. N-Car Mint Green



37633 DB V 1./2. Cl. N-Car Mint Green



**NEW
2022**



37636 DB V Control Car Wittenberg Mint Green





37660 DB IV Passenger Coach Bpmz 2. cl.



37665 ÖBB VI BR116 2. Cl. Coach Railjet



37666 ÖBB VI BR116 1. Cl. Coach Railjet

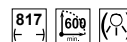

✘ 37662 DB IV Passenger Coach Bpmz 2. cl.



37663 DB IV Passenger Coach Apmz 1. cl.



37664 Flixtrain VI Passenger Coach

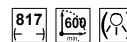

Interior lighting #36132
For all Cars available:  #36165

**NEW
2022**



37668 DB IV 2. Cl. Coach Bpmz Lufthansa

**NEW
2022**



37667 DB IV 1. Cl. Coach Apmz

REKO PASSENGER CARS

Available Interior Lighting: #36137, 36138
 Available for European Passenger Cars:  #36165



37650 DR IV Reko Bghwe 2. Cl. Coach



37651 DR IV Reko BDghwse 2. Cl. Combine



37652 DR IV Reko WRge Diner MITROPA



37655 DR III Reko 2. Cl. Coach



37656 DR III Reko 2. Cl. Combine



37657 DR III Reko Diner MITROPA



Prototype:

By the 1950's, the Deutsche Reichsbahn was in great need of modern passenger cars. Like the Deutsche Bundesbahn, the DR decided to upgrade existing 2- and 3-axle wooden Länderbahn coaches to contemporary standards. Each car was stripped down to its frame and rebuilt to a uniform 13,820 mm (45 ft) length, 3043 mm (10 ft) width, and 4000 mm (13 ft) height. Single doors were installed on the front right-hand side and every car received electric lighting. The first ReKo (ReKonstruktion) cars entered service in 1959, and after a trial period went into production in 1960. The cars spread quickly throughout East Germany and soon formed the backbone of DR's passenger car fleet. They became the quintessential commuter car and could be found in all metropolitan areas of the DDR, where some trains consisted of up to 10 cars. Retirement of the ReKo coaches began in the 1980s and finished in the mid-1990's.

Available Interior Lighting: #36131

Available for European Passenger Cars:  #36165



37680 DR IV Reko 3-Axle Coach Bage



37681 DR IV Reko 3-Axle Coach Bagtre

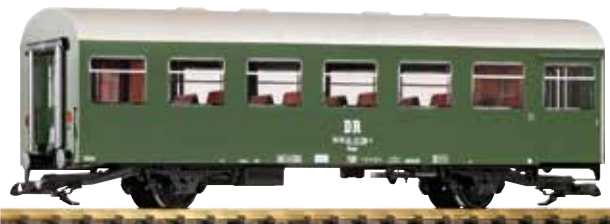

37682 DR IV Reko 2-Axle Coach Baage



 37683 DR IV Reko 3-Axle Baggage Dage

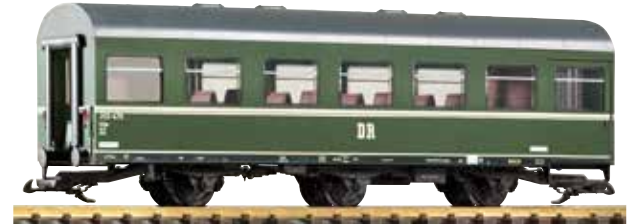

37684 DR III Reko 3-Axle Coach Bage



37685 DR III Reko 3-Axle Coach Bagtre



37686 DR III Reko 2-Axle Coach Bage



37687 DR III Reko 3-Axle Baggage Dage

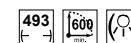

Available Interior Lighting: #36131

Available for European Passenger Cars:  #36165



 37610 DB IV Workshop Car 414



37600 DB IV 3-Axle Umbau 2. Class Car



37601 DB IV 3-Axle Umbau 1.-2. Class Car



37602 DB IV 3-Axle Umbau Combine

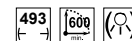

Available for European Passenger Cars:  #36165



37920 DB III 2-Axle 2. Cl. Coach



 37926 DR III 2-Axle 2. Cl. Coach



37927 DRG II 2-Axle 3. Cl. Coach



 37840 DR IV Luggage Van Pwg88



37842 DR III Baggage Car



PIKO introduced the outstanding smart measuring car in HO-Scale and ever since G-Scale enthusiasts have been asking for this innovation as well. Now PIKO has provided! You can now measure your entire garden railroad accurately from measurements of scale miles all the way down to a centimeter. Track gradients can also be measured. All measured data can be displayed in realtime on the SmartPhone app (Android or Apple iOS) or the PC app. Additional data like the average train speed can be saved and analyzed on your PC. Data is measured from every inch of trackage, not just visible track and the high-tech Measuring Car is based on actual DB AG Geometry Cars including prototypically accurate paint scheme and factory-installed interior lighting.



Integral display screen

- › Switchable lighting

Display of measured data

- › Actual train speed (cm/s, m/s, km/h, mph)
- › Distance traveled (cm, m, km, miles)
- › Total distance with zeroing function

Onboard data storage

- › Option to read measurement data without WiFi connection

Integral backup battery

- › Ability to measure dead track sections

Integral USB port

- › Memory read out
- › Battery charging port

Grade percentage measurement

Analog and digital operation

**NEW
2022**



37841 Measuring Car Pwg88

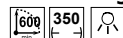

Preproduction model. Subject to change.



FREIGHT CARS

- > Precision engineering
- > Excellent running characteristics
 - > High level of detail and precise scale proportions
 - > Elaborate paint schemes
 - > Fine lettering



See this and more great freight cars on the following pages.



38775 Sunoco Tank Car



38747 Conoco Tank Car

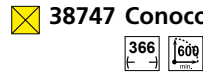

**NEW
2022**



38781 Texaco Tank Car 1975



**NEW
2022**



38782 Sinclair Oils Tank Car 71977



ORE CARS

Available for all American Freight cars:  #36164



 38912 D&RGW Ore Car with Ore Load



38913 SF Ore Car with Ore Load



 38911 PRR Ore Car with Ore Load



36311 Ore Car Load

Weather-resistant injection-molded plastic insert. Realistic representation of a load of raw iron ore. Made to fit PIKO ore cars. Light weight helps avoid the car becoming top-heavy and unstable.



 38914 UP Ore Car with Ore Load



Available for all American Freight cars: © #36164

**NEW
2022**



38933 Chessie-B&O Ore Car, 2-Pack

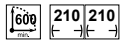

**NEW
2022**



38931 D&RGW Ore Car, 2-Pack

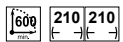

VINTAGE WARBIRDS HOPPER CARS



38902 Vintage Warbirds P-51 Hopper



38903 Vintage Warbirds P-47 Hopper



38909 Vintage Warbirds F4U Hopper



38910 Vintage Warbirds P-38 Hopper



38921 Vintage Warbirds B-25 Hopper



Adding to the Series!

Honoring the Greatest Generation
and the planes that made history.

- Photo-realistic graphics!
- Original licensed artwork!
- Produced only once!



38928 Vintage Warbirds Spitfire Hopper



38925 Vintage Warbirds SBD Hopper



38940 Vintage Warbirds C-47 Hopper



**NEW
2022**



36312 2-Bay Hopper Car Load

Weather-resistant injection-molded plastic insert. Realistic representation of a load of coal. Made to fit PIKO two-bay rib-side and offset-side hopper cars. Light weight helps avoid the car becoming top-heavy and unstable.



38916 PRR Rib-Side Hopper with Coal Load



38924 Chessie-C&O Rib-Side Hopper with Coal Load



38829 B&O Offset Hopper 220589



38880 NYC Covered Hopper 160729



Available for all American Freight cars:  #36164

**NEW
2022**



38917 D&RGW Rib Side Hopper with Coal Load



38934 CSX Rib-Side Hopper with Coal Load



 38919 UP Flag Hopper with Coal Load



**NEW
2022**



38918 SF Rib Side Hopper with Coal Load



38935 Easter Egg Mine Hopper





38825 PRR Steel Boxcar 81374

362 600



38831 UP Steel Boxcar 120152

362 600



38873 CNW Boxcar, 15355

362 600



38926 SF Steel Boxcar

362 600



38879 B&O Sentinel Boxcar

362 600



38885 CB&Q Friendship Train Boxcar

362 600

"AMERICAN TRADITIONS" REEFERS

PIKO

Available for all American Freight cars:  #36164

**NEW
2022**

The American Traditions series recalls many significant icons of American history, culture and heritage. Each car features original artwork commissioned from a fine artist exclusively for PIKO, and reproduced in beautiful full-color, as only PIKO can do.



38923 American Traditions Baseball Reefer



38922 American Traditions Betsy Ross Reefer



**NEW
2022**



38941 American Traditions John Henry Reefer



**NEW
2022**



38942 American Traditions Independence Reefer





36302 Container 20', Undecorated White

302 x 103 x 111 mm
11.9 x 4.0 x 4.4 "



38751 WP&YR Container Car

368 600



38764 USATC Humvee Transport 11212 with diecast vehicle

368 600



38732 SF Container Car

368 600

Available for all American Freight cars:  #36164



✘ 38756 RDG Bulkhead Flatcar with Pipe Load



✘ 38741 B&O Flatcar with Lumber Load



✘ 38740 SF Flatcar with Lumber Load



✘ 38755 PRR Bulkhead Flatcar with Pulpwood Load





38773 SF Flatcar w/Stakes, 2-Pack



38774 UP Flatcar w/Stakes, 2-Pack



38763 D&RGW Bulkhead Flatcar



38766 CR Bulkhead Flatcar 718906



Available for all American Freight cars:  #36164

All items on these two pages feature removable/positionable stakes.

**NEW
2022**



38778 D&RGW Flatcar w/Stakes, 2-Pack

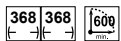

**NEW
2022**



38779 PRR Flatcar w/Stakes, 2-Pack



Due to their weight and the absence of pneumatic brakes, freight trains had to be slowed down, when necessary, one car after the other. Another risk of freight and passenger trains was caused by overheating bearings and oil lamps tipping over. Switches had to be worked, lighting provided and passengers and freight handled. The caboose served as working and living place for the indispensable conductors, signalmen, shunters, brakemen, locomotive engineers and firemen, especially on long-distance journeys. Furthermore, tools and spare parts were also stored and transported here. In order to have a better view, an elevated superstructure, called a cupola, was added to the roof of many cabooses. For shorter distances, a caboose without a cupola, called a transfer caboose, was often used.



38706 SF Work Caboose 110527 with Metal Wheelsets and Lighted Markers



Use the 36250 lighting kit to add interior lights to the cabin of this work caboose.



38862 SF Transfer Caboose 1207



**NEW
2022**



38907 D&RGW Wood Caboose



38906 PRR Wood Caboose



38948 UP Wood Caboose



Available for all American Caboose:  #36164

**NEW
2022**



38945 SF Wood Caboose

**NEW
2022**



38946 PRR Wood Caboose

 

**NEW
2022**



38947 D&RGW Wood Caboose

Available for all American Freight cars:  #36164



Just as on the prototype, this gondola has no end panels and the long pipes overhand the ends of the car, requiring an "idler" flatcar on each end. The 38778 D&RGW Flatcar 2-Pack is an excellent companion.



38749 D&RGW Pipe Gondola with Pipe Load



38754 PRR Low-Side Gondola with Roof Trusses



38735 D&RGW Sightseeing Car with Bench Seats



38753 WP&YR Sightseeing Car with Bench Seats



Prototype and Model:

During the 1920s, the Deutsche Reichsbahn received their first self-discharging hopper cars that were used for ballast service. The biggest innovation on these cars was a sophisticated system of hand-controlled chutes that allowed the operator to direct the flow of ballast to the inside or outside of the rail. When designing our G scale Otm hopper car, we decided that we would include this same feature on our model! You too can spot our G scale Otm at a worksite on your Garden railroad, and dump sand and fine gravel on your G scale right-of-way using the Otm's miniature chutes.



37850 Self-Unloading Hopper DR IV





37753 DB VI Flat w/2 20' Containers



37752 "Deutrans" DR IV Flat w/2 20' Containers



**NEW
2022**



 37011 ÖBB V Flat w/Container



37707 DB AG V Flatcar



Available for all Tarp Cars:  #36164



 37746 Mercitalia IV Shimmns Tarp Car

37720 Track Cleaning Car, 2 Track Cleaning Pads and 100 ml Cleaning Fluid included. See page 121 for additional track cleaning supplies.

**NEW
2022**



 37748 Wascosa VI Tarp Car Shimmns-tu 718

37724 DB V Tarp Car Shimmns Cargo

**NEW
2022**



37966 DR III G10 Boxcar Fit



**NEW
2022**



37965 DR III G10 Boxcar Born



**NEW
2022**



37967 DB IV 2-Axle Tank Car Eva



**NEW
2022**



37773 DR IV Coal Container Car w/Brake Platform





37955 DR III Stock Car, doors can be opened

600 350



37960 DB IV 2-Axle Boxcar w/Brake Platform

600 386



37961 DRG II 2-Axle Boxcar w/Brake Platform

600 386



37830 2-Axle Emergency Tank Car DR III

600 386



37956 2-Axle Tank Car Buna DR IV

600 350

Available for all 4-Axle Gondola:  #36164

Available for all 2-Axle Freight Cars:  #36165



37800 DB III Ore Car OOt96



37962 DR III Acid Tank Car w/Brake Cab



37964 DRG II 2-Axle Gondola



37963 DR IV 2-Axle Gondola



**NEW MOLD
2022**



CAD-drawing

**NEW
2022**

37970 Building Block Car (Building blocks not included in the package)



The imaginations of young (and not-so-young!) model railroaders should run wild at the thought of a train car that can be built and rebuilt any way they want it with the new PIKO building block car. Aspiring model railroaders can use their favorite building blocks; the possibilities are endless! Whether they are by themselves or with family and friends, younger modelers will always be creating new works of art on the building block car. Model railroading with PIKO has never been more fun!



37796 DR IV Cement Silo Car Gray Chassis



37749 FS IV Gondola Eaos



**NEW
2022**



37010 SBB VI Eaos Gondola Gray





PIKO POWER & ACCESSORIES

- > Multiple Systems / Multiple Options:
 - > Power for Indoors and Outdoors
 - > Simple R/C for All Power Types
 - > Factory-Equipped R/C
 - > PIKO G-Digital for DCC
 - > Components for Battery, DC, DCC and R/C





35028 R/C Analog Track Power Set, 5A / 120V w/Pocket Remote

- **NO Loco Modifications**
- **Run almost any Analog DC train.**

Set includes 22V / 5A / 120V Transformer, R/C Controller and Pocket Remote.

- **Easy:** Simple 4-button Pocket Remote gives you precise control of speed and direction, an emergency stop for safety and a fixed DC accessory output on/off, all from a compact remote control.
- **Flexible:** 8 selectable channels give you options – Use the 8 channels to control locos or consists independently, or set R/C Controllers to the same channel to control multiple tracks at once.
- **Powerful:** The 22 Volt / 5Amp Transformer provides big power. The R/C Controller will provide up to 4.5 Amps to the track and up to 2.0 Amps of fixed DC for accessories. (5 Amps max continuous output.)
- **Reliable:** The Pocket Remote offers up to 80' / 25m wireless walk-around range from the R/C Controller. Uses radio control so it works in daylight and around corners - no need for "line of sight".

The 35028 is not recommended for use with decoder-equipped locomotives.



35040 R/C Loco Receiver, 3,5 A, w/Pocket Remote

The 35040 R/C Loco Receiver offers all the operational features of the R/C Controller in the 35028 set, with extra benefits:

- The R/C Loco Receiver is compact and fits most G-Scale locos. The main receiver board is only 2.8" x 1.2" x 0.6".
- Includes two relay-type function contacts for controlling horn/whistle and bell on a separate sound unit.
- Designed to be easily battery-powered (minimum 7v batteries. Batteries not included)
- Alternately, the Receiver can be powered by a fixed, well-filtered DC supply of 7 to 22 volts, such as a DC voltage on the track.
- The Receiver has simple, user-friendly connections for motor/lighting power and the two function outputs.
- Includes 35041 Pocket Remote - see features on page 109

With the 35040 R/C Loco Receiver and batteries installed in your G-Scale loco, the included pocket remote allows you to operate your train virtually anywhere - over dirty track, non-powered track, even across the floor!

35040 is not recommended for use with decoder-equipped locomotives





35041 R/C Pocket Remote

Additional remote for 35028, 35040, 35042 and R/C starter sets. Extra remotes are ideal for more operators and can replace lost or damaged remotes. 8 selectable R/C channels allow for multiple trains and/or operators. Includes push-button controls for two relay-type functions such as horns/whistles and bells. Up to 80' / 25m range, indoors or outdoors.

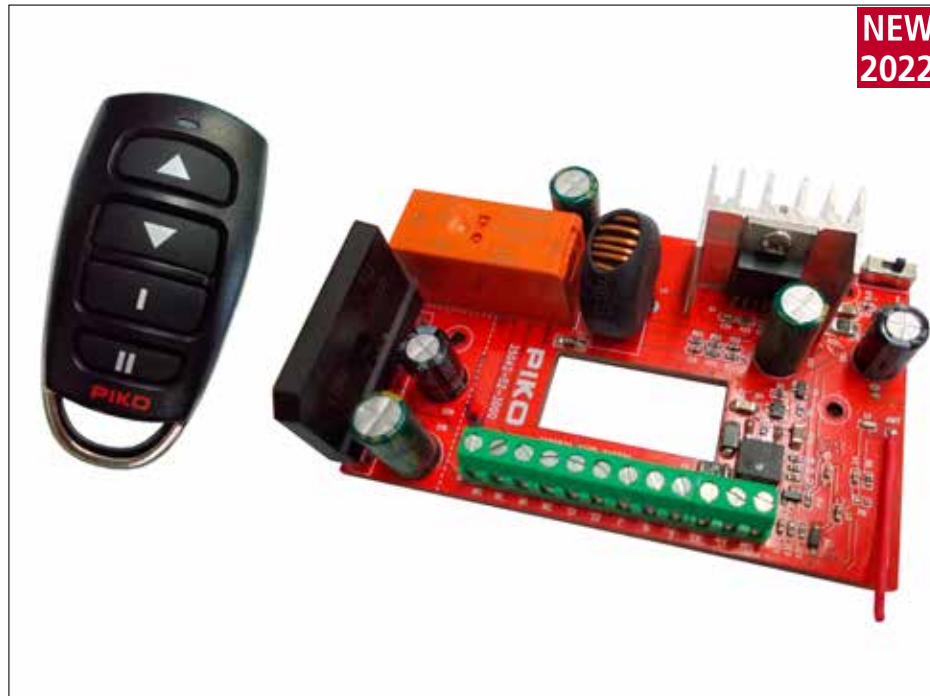

**NEW
2022**

35042 R/C Loco Receiver 5A, Pure DC with Remote

The 35042 R/C Loco Receiver takes onboard PIKO R/C to a new level!

- › The Receiver provides up to 5A (6A peak power) with a "Pure DC" output safe for the Analog operation mode of most DCC decoders, including the popular PIKO 36220 steam sound decoder kit.
- › The Receiver board is designed for easy installation inside many G-Scale locos. The Receiver board measures 3.38" x 2.16" x 1.06" (86x55x27mm)
- › Includes two relay-type function contacts for controlling horn/whistle and bell on a separate sound unit.
- › The built-in rectifier allows the Receiver board to operate on 12-18V AC / 12-24V DC 6A for usage with digital equipment (for good performance min 18V AC / DC recommend), from either onboard batteries or constant track voltage.
- › Includes Mode switch to select voltage output range, starting either at 0.5V for locos without internal voltage drop circuits, or at 6V for decoder-equipped locos with a higher startup voltage.
- › Receiver PCB includes wiring access cut-out for easy installation in locations such as tenders with wires coming up through the floor.
- › Easy screw-terminal connections for motor, lighting and two function outputs.
- › 8 selectable R/C channels. Set up to 8 different locos to different channels for independent operation, or set any number of locos to the same channel for multiple-unit lashups.
- › Includes 35041 Pocket Remote - see features above.



Another industry First from PIKO!

25-Ton diesel locos factory-equipped for full battery-powered operation, with PIKO R/C and realistic TCS digital sound built-in. Run the train over any track - clean, dirty or unpowered, even across the floor! It's all controlled from the convenient Pocket Remote, included with the loco.

Six standard size 'AAA' batteries (not included, high-capacity rechargeables are recommended) allow for long running time. The quick-change battery clip is located inside the engine hood and the front panel snaps off for easy access.

8 selectable R/C channels allow running multiple locos independently, or controlling multiple locos together in one train consist. What could be more fun than one PIKO 25-Tonner? A double-header, triple-header, or more!

In addition to the bright directional LED constant lights and cab interior light, the highly realistic digital sound is completely new, a joint development of PIKO and TCS, a name already well-respected for digital sound decoder technology. Numerous authentic sounds function automatically. And if the powerful high-fidelity sound becomes a bit much, there's an easily-reached volume control in the loco cab.

Press a button to turn on the bell as the train pulls out of a station. Press again to turn it off. Press and hold another button to blow the horn as long as desired. Give the correct two blasts when starting in forward, and three in reverse, or a few quick warnings to clear the tracks. Even blow the grade crossing pattern of two longs, a short and a long blast. And this realistic control is easy with just one hand, at up to 80' range - unaffected by daylight and big enough for the great outdoors.

All these locos come with the easy-to-use Pocket Remote. See 35041 on page 109 for more details.

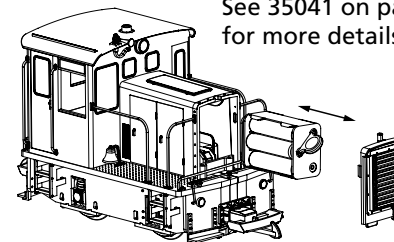

Clean Machine R/C

The 38506 "Clean Machine R/C" adds another dimension - a battery-powered, radio-controlled track cleaning loco. Track cleaning operation is simple - just let the loco run around your layout (either in forward or reverse) till even heavily oxidized track is polished clean. Once the Clean Machine has cleared the way, track-powered locos can run smoothly. With the convenience of PIKO R/C built-in, you can run the loco into a stub-end siding track and then back out of the siding, or park the loco in the engine house when you're done cleaning track. This loco can also function as a normal loco, just like a real "25-Tonner", pulling a few cars around the layout.



38506 Clean Machine R/C operation, completely battery-powered (Non-Sound)



38509 SF 25-Ton Diesel Battery R/C w/Sound

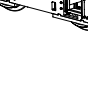

38510 PRR 25-Ton Diesel Battery R/C w/Sound

Pre-Production Image:
Actual Item Subject to Change



38511 US Army 25-Ton Diesel Battery R/C w/Sound



38512 KLV Thumper 25-Ton Diesel Battery R/C w/Sound

ECONOMICAL POWER, ALL IN ONE PACKAGE



35027

35027 45 Watt Analog Power Set, 120 V

Transformer: 120 V AC
Safety-Approved
Switching Power Supply
Output 24 V DC / 45 VA
Electronic Throttle:
Output 0-22 V DC / 1.5 A,
Constant 16 V DC / 0.4 A

BIG POWER FOR LARGER LAYOUTS



35002

35002 Analog Throttle

Electronic controller for analog operation. Requires a transformer, such as 35024.
Input: max. 18 V / 5 A AC or max. 24 V / 5 A DC
Output: 0-22 V / max. 5 A DC
Add wireless control for up to 8x 35002 Analog Throttles with the 35037 Navigator Remote and 35038 Wireless Receiver. See page 112.



35024

35024 Power Supply 120 VA

The ideal power supply for the 35002 Analog Throttle. Provides a full 5 amps output at 24VDC. Not for use with Digital systems.
Input: 120 V AC
Output: 24 V / 120 VA DC

SEPARATE POWER COMPONENTS

35006 Basic Analog Throttle

Electronic controller for analog operation
Requires a transformer, such as 35025.

Input:
max. 24 V / 1.9 A DC only
Output:
0-22 V / 1.5 A DC,
constant 16 V DC, 0.4 A



35006



35025

35030 Analog Reversing Unit

The PIKO Analog Reversing Unit contains:

- Splash-proof electronics
- Insulated track joiners
- Track hook-ups with cable

Using the Analog Reversing Unit, your train can automatically shuttle between two train stations.

It features the following functions:

- Smooth acceleration and deceleration
- Adjustable waiting time in train stations
- Overload and short circuit protection
- Requires a well-filtered DC power supply of 12-24 Volts.

Notice! This product cannot be used with digital/DCC, multi-train systems.



35030

35025 Power Supply 45 VA

Power supply for PIKO analog throttle 35006 and Switch Control Boxes 35260 and 35261

Input: 120 V AC
Output: 24 V / 45 VA DC

TAKE CONTROL OF YOUR LAYOUT



35260

35260 Switch Control Box

Weather-resistant control for operating
4 switches or signals
Input: 0-24 V DC-only



35261

35261 On/Off Control Box

Weather-resistant control with 4 double-pole on/off switches to control 4 different electric circuits, such as tracks or lights.
Input: 0-24 V AC or DC

The PIKO G-Digital System gives independent control of multiple trains on the same track. PIKO G-Digital is fully NMRA-compliant DCC (Digital Command Control) and can reduce complex block wiring and insulated track sections. Track voltage is kept constant at roughly 22V and each locomotive decoder receives signals and responds to user commands, including operating lighting functions or installed sounds.

The PIKO G-Digital System includes four main components:

- › 35020 Transformer (Providing reliable power to the system)
- › 35010 Digital Central Station (The brain, sending commands to the track)
- › 35037 Navigator Remote (An ergonomic remote)
- › 35038 Wireless Receiver, Optional (For wireless operation)

Switch Decoders, Boosters and more devices can always be added on to customize your layout.

35037 Navigator Remote

The Navigator Remote can be used with the PIKO G-Digital System or the 35002 Analog Throttle. The large backlit display enables clear operation. The Navigator Remote allows assigning each loco an icon and name for clear identification. It can also control switches on DCC layouts.

The Navigator Remote can be connected via the included cable or can be operated wirelessly by adding the 35038 Wireless Receiver.



INFO

- › Large backlit display with easy, menu-based control
- › Locomotive configuration with alpha-numeric names and pictograms
- › 10,239 locomotive addresses
- › 14, 28 and 128 speed step capability
- › 2048 switch/accessory addresses
- › NMRA functions F1 through F24
- › Parallel and serial function triggering capability for compatibility with older equipment
- › Bi-directional communication with the Central Station
- › Split-screen display allows simultaneous control of two locomotives or a locomotive and an accessory
- › Multi-protocol capable: PIKO, Lenz Xpressnet and DiMAX
- › Multi-operator capable: Up to 8 Navigators can be used simultaneously with the Wireless Receiver (#35038)

35010 Digital Central Station

The Digital Central Station receives signals from the Navigator Remote and controls operations on your layout. The Digital Central Station takes the input from one or more Navigators and converts it to digital commands that it sends out with track power. The digital commands are addressed to specific decoders, and decoders ignore any command not addressed to them, so only the selected loco or accessory will react to your input.

Input: 16-20 V DC, max. 5 A

Output: Up to 27 V DCC regulated, max. 5 A



35010

35020 Power Supply 120 VA

The ideal power supply for the 35010 Digital Central Station and 35015 Digital Booster. Provides a full 6 Amps output at 20V DC.

Input: 120 V AC

Output: 20 V / 120 VA DC



35020

35038 Wireless Receiver

The splash-protected Wireless Receiver converts the radio signal from the Navigator into either a digital signal for the 35010 or an analog signal for the 35002. The Receiver includes the correct cables and employs bidirectional FM radio technology that allows for reliable operation for up to 300 feet. (100m)



35038

Programming, Installing, & Testing are easy and clear

The new PIKO SmartProgrammer makes it easy to download your own sound files onto a decoder using a programming track or WLAN. With the Smart Decoder app for Windows PC, Android and iOS devices can have their digital parameters quickly configured without first having to attend a programmer's seminar. The PIKO SmartTester provides instant feedback on decoder settings using integral LEDs, a test motor, a speaker, or the appropriate App. It tests N, TT, and HO decoders as well as decoders from larger scales.

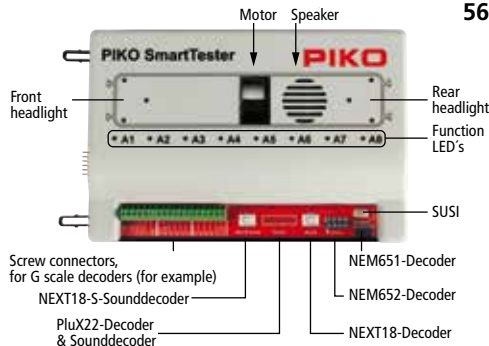

56416 PIKO SmartTester

- Quick and easy decoder function testing
- Instant feedback from activated functions via the integral speaker, motor, and LEDs for functions A1 to A8 as well as the front and rear headlights
- HO, TT, and N scale decoder receptacles as well as the potential to test larger scale decoders and SUSI interfaces
- Can be used in-tandem with the PIKO SmartProgrammer via a plug connection



56415 PIKO SmartProgrammer

- Set digital parameters for your decoder
- Simple and Extended Function Mapping
- Transfer sound files via an integrated WLAN module or USB cable
- Easily upload decoder data via the programming track to the model
- Upload sound files quickly with the SUSI interface
- Upload your own sound files like station announcements, radio chatter, and more
- Trouble-free operation via free software for Windows PC as well as the app for iOS and Android devices
- Can be used as a "mini DCC system" for automatic train movements

The PIKO Digital System allows for simultaneous independent control of multiple locomotives on a track section. This requires the locomotives to be fitted with a digital decoder. All current PIKO locomotives are designed for easy installation of a PIKO locomotive decoder. Normally this entails a simple swap of the main circuit board for the appropriate PIKO locomotive decoder.



Simply swap the main circuit board for the PIKO locomotive decoder and move the hookup wires from the screw terminals on the circuit board to the respective screw terminals on the decoder.

All PIKO SmartSound Decoder XP 5.1 shown here offer the same features

The main features are:

- > For DC and bell armature motors rated up to 5 A
- > 14, 28, and 128 speed steps depending on the DCC format
- > 9999 digital locomotive addresses
- > RailCom® and RailCom Plus®- compatible
- > mfx®-compatible
- > Corresponds to current RCN (European Digital Manufacturers Association) standards
- > Generously sized energy capacitors
- > Adjustable min., med., and max. speeds
- > Adjustable extended motor speed curve
- > Switching (shunting) gear mode
- > 3 adjustable acceleration and braking delays, each switchable via F0 - F68
- > Directional Rule 17 lighting
- > 12 individual function outputs with 8x logic that are optionally directional-dependent
- > 4 servo connections for model animation
- > Light and function outputs adjustable for analog operation
- > Optional secondary dimming setting for A0 to A12; switchable
- > Simple function mapping for F0 - F12
- > Extended function mapping for F0 - F68 for switching linked function outputs
- > Locomotive lights facing the first car of the train can be switched off
- > All function outputs have blinking options via four flash generators
- > All function outputs can be triggered automatically via a variety of settings
- > Load-dependent smoke generator
- > Firebox light settings with adjustable parameters
- > Automatic coupling/uncoupling and programmable switching scenarios
- > Light and function outputs can be hidden
- > Energy-efficient lamp effect
- > Adjustable fluorescent lighting effect
- > 8 PWM banks for North American train lighting effects like Mars Lights, Gyra Lights, Strobes, etc.
- > SUSI socket for additional PIKO sound modules
- > Braking with DCC brake signal, analog DC brake signal, or ABC brake signal including shuttle train operation
- > Constant braking distance measured in cm
- > Auto-adaptive motor control
- > Motorola data format with 4 addresses for functions F1 - F12
- > Conventional DC and AC analog operation
- > Decoder size: 54 x 28 x 13 mm (2.1" x 1.1" x 0.5")
- > Connector PCB size: 68 x 28.5 x 13 mm (2.7" x 1.1" x 0.5")
- > Combined size: 68 x 28.5 x 16 mm (2.7" x 1.1" x 0.6")

PIKO SmartProgrammer App



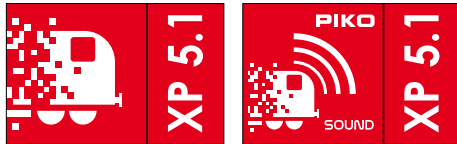

36500 SmartDecoder XP 5.1
 Features:
 • Dimensions: 54 x 28 x 13 mm

36511 XP 5.1 Connector PCB with wire leads for G scale Taurus and BR 218
 Features:
 • Locomotive-specific wiring via the carrier board
 • Dimensions: 68 x 28,5 x 13 mm

36512 XP 5.1 Connector PCB with wire leads for G scale BR 80
 Features:
 • Locomotive-specific wiring via the carrier board
 • Dimensions: 68 x 28,5 x 13 mm

36505 SmartSound Decoder XP 5.1 Programmable
 Features:
 • Dimensions: 54 x 28 x 13 mm

36510 Connector PCB for G-PSD XP 5.1
 Features:
 • Dimensions: 68 x 28,5 x 13 mm

PIKO's latest digital decoder, the SmartDecoder XP 5.1 (PSD XP 5.1 for short), offers serious model railroaders a wealth of digital features. The PSD XP 5.1 is fully compatible with the latest RCN (European DCC Manufacturers' Association) standards.

PSD XP 5.1 with loud-speaker

| Steam locos | Art.-Nr. | BR 118 | 36527 |
|----------------|----------|-----------------------------------|----------|
| BR 24/ BR 64 | 36522 | BR 132 | 36526 |
| BR 50 | 36530 | BR 199 / V 100 | 36540 |
| BR 80 | 36537 | BR 218 | 36535 |
| BR 94 | 36521 | V 36 / V 20 | 36524 |
| BR 95 | 36528 | V 60 / BR 260 | 36539 |
| Electric locos | Art.-Nr. | Railcars | Art.-Nr. |
| BR 103 | 36529 | TEE VT 11.5 (two loud-speaker) | 36543 |
| BR 194 | 36541 | | |
| Taurus | 36534 | | |
| Diesel locos | Art.-Nr. | VT98 Railbus | 36536 |
| BR 106 | 36533 | | |

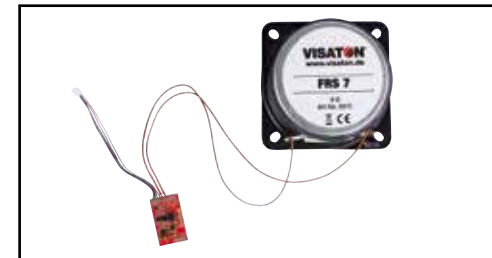

G-PSD XP 5.1 Sound with loud-speaker

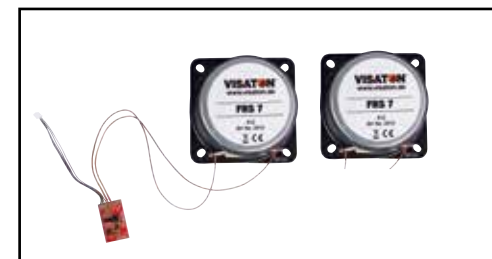

G-PSD XP 5.1 Sound with two loud-speakers

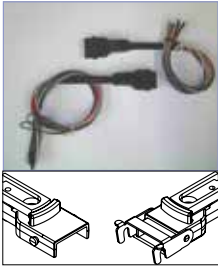

36032 12-Pole Electrical Plug Coupler, 1 Pr
 Coupler with integrated 12-pole electrical connection. This coupler can replace the standard hook and loop coupler on most cars and locomotives. Among other things it can be used to power and control Interior Light throughout a train.

36033 Rigid Coupler Non-Electrical, 1 Pr
 Same as 36032 without electrical contacts and cables

Mounting the Electrical Coupler example: Silver Coin Coach

1. Unscrew existing coupler and remove from truck.
2. Place new coupler holder on truck and screw down.
3. Route wires beneath axle and plug electric coupler head into holder.



36220 American Steam Sound Kit DC / DCC
 This kit is ideal for the non-sound PIKO Mogul Steam Locos. It can also be adapted to many other steam locos. Simple screw-terminals for all connections ease installation. The heart of the kit is a state-of-the-art high-quality digital steam sound decoder developed exclusively for PIKO by SoundTraxx®. It provides full-featured operation on Analog DC as well as Digital DCC. The sound decoder provides outputs for front and rear lights, as well as a regulated 5V output for a smoke unit (#36142, not included). A small separate circuit board provides a manual sound volume control knob as well as an on/off switch for the smoke unit. The included reed switch sensor allows triggering of bell and whistle signals via track magnets (#35268, not included). The sound decoder can be configured using a DCC system to fit the desired characteristics of the loco. For example, one of three different whistle tones can be selected and the exhaust "chuff" rate can be set to closely match the rotation of the loco drive wheels. This programming remains in effect on Analog DC operation as well as DCC.



36221 American Steam Sound Kit, Analog
 In conjunction with the optional Reed Switch (#35267) Track Magnets (#35268) can trigger bell and whistle sounds.

36194 Analog-Sound Kit BR 80
 In conjunction with the optional Reed Switch (#35267) Track Magnets (#35268) can trigger bell and whistle sounds.

| ITEM-NO. DESCRIPTION | | | ITEM-NO. DESCRIPTION | | | ITEM-NO. DESCRIPTION | | |
|----------------------|---|---|----------------------|---|---|----------------------|--|---|
| 36000 | Motor, 4 Wheel Gearbox Taurus, BR 218, V 100 |  | 36050 | Arch Bar Freight Trucks, 1 pair |  | 36113 | Wheel Wipers right/left Schienenbus, Railbus |  |
| 36001 | Motor, 6 Wheel Gearbox BR 80, US Steam Loco, |  | 36051 | Bettendorf Freight Trucks, 1 pair |  | 36114 | Pickup shoes, Railbus (Set of 2) |  |
| 36004 | Motor w worm (1 thread) BR 194 w white or dark gears |  | 36052 | American Passenger Trucks, 1 pair |  | 36115 | Wheel Wipers right/left, V 60 / BR 260 |  |
| 36005 | Motor w worm (1 thread) Mogul w white or dark gears BR 80 / 0-6-0T w/Analog Sound, Old Mogul |  | 36180 | Idler gears (3 pcs.) Taurus, BR 218, V 100, V 199, Rail Bus, 25-Ton Diesel |  | 36117 | Pickup shoes, BR 194 (Set of 2) |  |
| 36006 | BB Motor w worm Taurus, V100, BR 194 w red gears |  | 36181 | Idler gears (3 pcs.) BR 80, Old Mogul, 0-6-0, V 60 / BR 260 |  | 36118 | Carbon brushes, BR 64/24 (Set of 8) |  |
| 36007 | BB Motor w worm BR 80, Mogul, Camelback, TEE, V199 w/ Red Gears |  | 36182 | Idler Gear for BB BR 194 Motor 36006, 3 Pc Set |  | 36142 | Smoke Unit 5 V, for analog or digital, operate only with #36143 voltage regulator |  |
| 36008 | BB Motor w gear Rail bus |  | 36183 | Idler Gear for BB Mogul Motor 36007, 3 Pc Set |  | 36143 | Voltage regulator 5 V for Smoke Unit #36142 |  |
| 36009 | BB Motor w worm V 60 |  | 36184 | Idler Gear for BR 64 / BR 24 2 Pc Set |  | 36150 | Single-Arm Pantograph complete, Taurus |  |
| 36020 | BB Motor w worm BR 24 |  | 36200 | Engineer Figure |  | 36151 | Scissor Pantograph complete, BR 194 |  |

| ITEM-NO. DESCRIPTION | | ITEM-NO. DESCRIPTION | | ITEM-NO. DESCRIPTION | |
|----------------------|--|---|-------|---|---|
| 36070 | Traction Wheelset Taurus |  | 36077 | Hard-chrome plated Center wheelset BR 80, red |  |
| 36071 | Traction Wheelset BR 218, V 100, V 199 |  | 36078 | BB plated wheelset 0-6-0T, black, only for Gearbox 36107 |  |
| 36072 | Traction Wheelset Taurus Hard-chrome plated BB Traction Wheelset Taurus, only for Gearbox 36104 |  | 36079 | Hard-chrome plated Center wheelset 0-6-0T, black |  |
| 36073 | Wheelset Taurus Hard-chrome plated BB Wheelset Taurus, only for Gearbox 36104 |  | 36080 | BB geared wheelset BR 194, black |  |
| 36074 | Hard-chrome BB Traction Wheelset BR 218, V 100, V 199, only for Gearbox 36105 |  | 36081 | BB plated traction wheelset BR 194, black |  |
| 36075 | Hard-chrome plated BB Wheelset BR 218, V 100, V 199, only for Gearbox 36105 |  | 36082 | BB plated wheelset BR 194, black |  |
| 36076 | BB Geared Wheelset for BR 80, red Hard-chrome plated, only for Gearbox 36106 |  | 36083 | BB plated traction wheelset BR 194, black |  |
| 36084 | BB plated wheelset BR 194, red |  | 36085 | BB plated traction wheelset BR 194, red |  |
| 36160 | Plastic Wheelset, 2 pcs |  | 36162 | Plastic Wheelset, 3 pcs |  |
| 36164 | Metal Wheelset, 30 mm, 2 pc Hard-chrome plated For all American cars |  | 36165 | Metal Wheelset, 35 mm, 2 pc Hard-chrome plated For many European cars |  |
| 36166 | Metal Wheelset, red, 30 mm, 2 pc Hard-chrome plated |  | | | |

36091 Crankpins – Mogul Wheels
Set of 6 metal screw-type replacement crankpins. Nickel-plated screws. Fits large 45 mm (1.77") diameter "Mogul" loco wheels.



36093 Crankpins – Starter Set Wheel:
Set of 6 metal screw-type replacement crankpins. Nickel-plated screws. Fits small 36.5 mm (1.44") diameter starter set, 0-6-0T and "Mini-Mogul" loco wheels.



36094 Crankpins – BR80 Loco Wheels
Set of 6 metal screw-type replacement crankpins. Dark nickel-plated screws. Fits small 36.5 mm (1.44") diameter starter set BR80 loco wheels.



| ITEM-NO. DESCRIPTION | | | ITEM-NO. DESCRIPTION | | | ITEM-NO. DESCRIPTION | | |
|----------------------|--|---|----------------------|---|---|----------------------|---|---|
| 36167 | BB Metal Wheelsets w/ Pickups, 30 mm, 2 Pcs For all American cars |  | 36175 | Center Wheelset for 0-6-0T 0-6-0 & Mini-Mogul |  | 36042 | Traction Tires 4 pcs BR 64 3,2 x 44 mm |  |
| 36168 | BB Metal Wheelsets w/ Pickups, 35 mm, 2 Pcs For many European cars |  | 36176 | Wheel set w gear V 60 / BR 260 |  | 36044 | Traction Tires 4 pcs GE 25-Ton 3,2 x 30 mm |  |
| 36170 | Geared Wheelset Taurus |  | 36177 | Traction Wheelset V 60 / BR 260 |  | 36030 | Standard Coupler 1 Pc complete |  |
| 36171 | Geared Wheelset BR 218, V 100, V 199, Rail Bus |  | 36178 | BB Geared Wheelset Hard-chrome plated BR 194 |  | 36090 | Set of screws (20 pcs.) |  |
| 36172 | Geared Wheelset BR 80 |  | 36179 | BB Traction Wheelset Hard-chrome plated BR 194 |  | 36110 | Standard Pickup shoes (Set of 2) Taurus, BR 218, BR 80, Mogul, 0-6-0, Camelback, V100/199 |  |
| 36173 | Idler Wheelset BR 80 |  | 36040 | Traction Tires 4 pcs V 60 / BR 260, Mogul 34 x 41 mm |  | 36111 | Wheel Wipers right/left Taurus, BR 218, V 100 |  |
| 36174 | Geared Wheelset 0-6-0 & Mini-Mogul |  | 36041 | Traction Tires 4 pcs BR 218, V 100, V 199 28 x 34 mm |  | 36112 | Wheel Wipers right/left Mogul, 0-6-0, Camelback, V199 |  |

36145 Pantograph Servo Motor
one for each pantograph (max. 2 servo motors) to control with decoder PIKO SmartDecoder 4.1 G #36125



36320 Extra weight, 2 pieces



35267 Reed Switch Assembly
For triggering bell and whistle functions on most PIKO sound units, via #35268 Track Magnets.

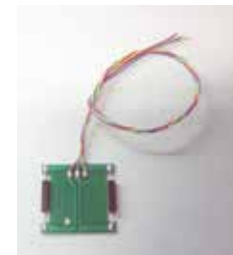

| ITEM-NO. | DESCRIPTION | |
|----------|---|---|
| 36130 | Interior Light Rail Bus |  |
| 36131 | Interior Light Umbau Cars |  |
| 36132 | Interior Light Silver Coin Cars |  |
| 36133 | Interior Light VT 11.5 VT 11.5 End Car |  |
| 36134 | Interior Light VT 11.5 VT 11.5 Middle Car |  |
| 36135 | Interior Light US Passenger Car |  |
| 36136 | Interior Light US Wood Drover's Caboose |  |
| 36137 | Interior Light Reko Coach |  |

| ITEM-NO. | DESCRIPTION | |
|----------|---|---|
| 36138 | Interior Light Reko Combine |  |
| 36139 | Interior Light Silver Coin Control Car |  |
| 36250 | Interior and Marker Light Kit, Work Caboose |  |
| 36012 | Wired LED BR 218 |  |
| 36013 | Wired LED BR 80, US Steam Loco 0-6-0 |  |
| 36014 | LED Lighting Set, 6 LEDs V 60 / BR 260 |  |
| 36015 | Replacement Light Set - 6 LEDs V 100, V 199 |  |
| 36016 | Add-On Rear Light Set - 4 LEDs V 100, V 199, BR 218 |  |

| ITEM-NO. | DESCRIPTION | |
|----------|---|---|
| 36017 | Interior Light for drivers cab and Engine bay |  |
| 36104 | BB Motor Block complete, Taurus |  |
| 36105 | BB Motor Block complete BR 218, V 100 |  |
| 36106 | BB Motor Block complete BR 80, red |  |
| 36107 | BB Motor Block, 0-6-0T & Mini-Mogul |  |
| 36108 | BB Retrofit Motor Block BR 194, with BB motor and revised gear ratios |  |
| 36109 | BB Motor Block, New Style Complete, Mogul |  |



35421 Mini-Hacksaw
With low-wear metal-cutting blade. Ideal for cutting PIKO G track rails.



36039 Uncoupling Wand
For easy uncoupling of standard hook-and-loop couplers on most G-Scale trains



36215 Conductive Paste, 50 ml



36216 Gear Grease, 50 ml



35420 Set Screwdriver, 4 Pcs.
High-precision, suitable for PIKO G items. Contains 2 Phillips, no. 0 and 1 and 2 Flat Blade Screwdrivers 2,5 mm and 4 mm.



36210 Smoke & Cleaning Fluid, 250 ml



35412 Track Cleaning Pads, 10 Pcs., 140 mm x 100



35413 Track Polishing Pads, 2 Pcs., 140 mm x 100 mm



56301 Oil for Locos, 50ml



35411 Track Cleaning Set
Contents:
1 Track Cleaning Block
5 Track Cleaning Pads
100 ml Track Cleaning Fluid



35414 Track Cleaning Fluid, 250 ml



38506 Clean Machine R/C operation, completely battery-powered



See page 36 for more info



35416 Track Cleaning Shoes, Clean Machine, 2 sets



37720 Track Cleaning Car, 2 Track Cleaning Pads and 100 ml Cleaning Fluid included



MODEL BUILDINGS

- > Realistic detailing
- > Accurate fit
 - > Realistic coloring
 - > Parts molded in multiple appropriate colors – no painting needed
- > Easy assembly
 - > Weathered parts on many buildings
 - > Comprehensive, easy to understand instructions





62040 "Rosenbach" Station

With its rural architecture, pleasant warm colors, pretty window shutters and benches under the little awning, this station recalls a genuine piece of railroading romance thought to have been lost for ever. We recommend the baseplates #62005 to enhance the model (1 set).

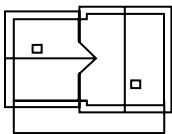

370 x 240 x 240 mm
14.6 x 9.4 x 9.4 "



62041 "Rosenbach" Switch Tower

The control-room with windows in every direction houses the lever frames that operate the switches and signals. Typical of this type of tower is the filigreed outside staircase and handrail. We recommend the baseplates #62005 to enhance the model (1 set).

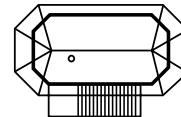

260 x 200 x 410 mm
10.2 x 7.9 x 16.1 "



62033 "Rosenbach" Signal Bridge

In order to provide the engineer with an unobstructed view of the signals, many railroads used special signal bridges. The steel bridge is weathered and carries two adjustable semaphore type signals.

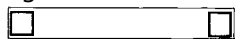

55 x 485 x 300 mm
2.2 x 19.1 x 11.8 "

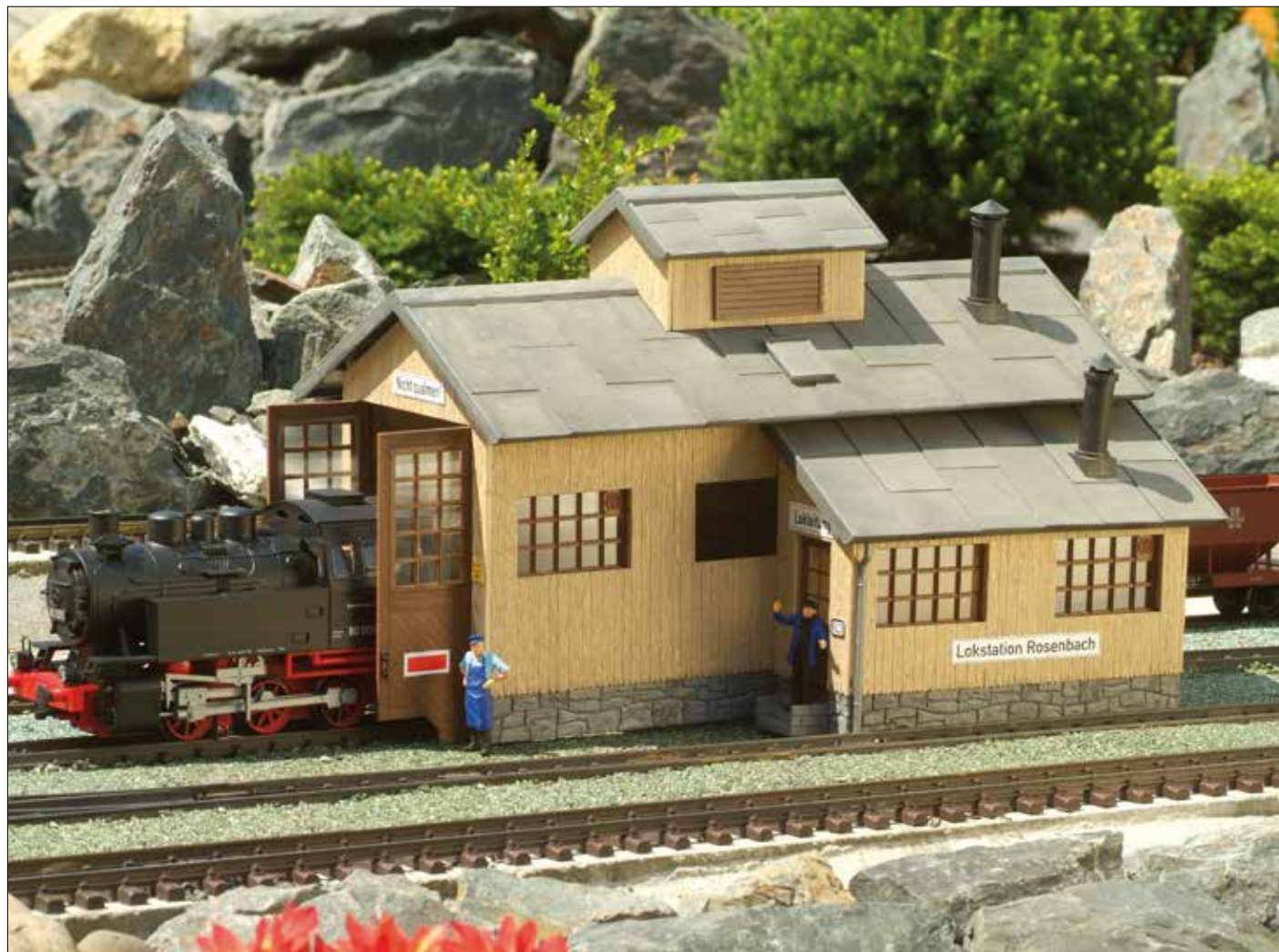

62042 "Rosenbach" Engine Shed

The shed has large double doors and a roof with a louvred superstructure for ventilation. The annex houses the local engine dispatcher's office. Doors can be opened and closed.

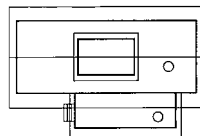

290 x 500 x 350 mm
11.4 x 19.7 x 13.8 "

62029 Blue Creek Valley Station

The cozy station provides a welcome retreat from the weather for passengers awaiting for the next train. The building is realistically weathered and has opening doors.

We recommend the baseplates #62005 to enhance the model (1 set).

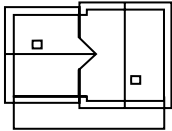

370 x 240 x 240 mm
14.6 x 9.4 x 9.4 "



62008 Sonneberg Goods Depot

Wooden ramps on both sides of the building aide the loading and unloading of freight cars. At the frontside is a fully operational roll-up door while a wooden door on the back allows for handling larger goods.

We recommend the baseplates #62005 to enhance the model (1 set).

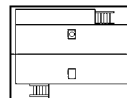

390 x 526 x 370 mm
18.9 x 20.7 x 14.6 "



62005 Baseplates with Cobbled surface
The set consists of two baseplates that provide a stable foundation for PIKO model buildings.

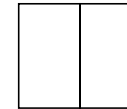

One plate:
460 x 267 x 10 mm
18.1 x 10.5 x 0,4 "



62006 Platform Sections with Cobbled surface

The crossing section kit is an ideal weather-resistant addition to the Covered Platform #62004 and "Neustadt" station #62030. (tracks not included)

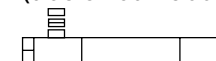

1138 x 174 x 10 mm
44.5 x 6.9 x 0.4 "

62030 Neustadt Station

① The station has many distinctive features: decorative brickwork at the corners, large decorated pillars in the entrance area, a hipped roof and an awning with wrought iron detailing. The doors can be opened and closed. We recommend the set of baseplates #62005 to enhance the model (1 set).

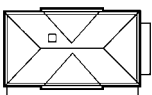

550 x 355 x 400 mm
21.6 x 14.0 x 15.7 "

62004 Covered Platform

② The platform is weather-resistant and can be placed alongside the track or between adjacent tracks. That way a station can have two or more parallel tracks with platforms.

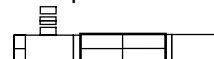

550 x 355 x 400 mm
21.6 x 14.0 x 15.7 "



62074 Streitberg Passenger Shelter

Located in the Wiesent Valley in Frankonian Switzerland the Streitberg passenger shelter protects passengers from the hot sun or pouring rain. The kit is equipped with opening doors. Benches as well as picnic tables are included.

We recommend the baseplates #62005 to enhance the model (1 set).



250 x 340 x 150 mm
9.8 x 13.4 x 5.9



62032 "Neustadt" Railway Footbridge

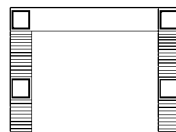

485 x 360 x 300 mm
19.7 x 14.8 x 11.8 "



62075 Diesel Locomotive Filling Station

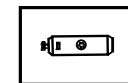

270 x 175 x 110 mm
10.6 x 6.9 x 4.3 "



62076 Coaling Station

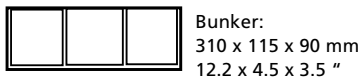
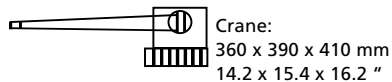

62113 Utility Buildings

The kit includes two weathered utility buildings with opening doors.

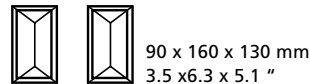

62296 Load - Crates & Pallets

The kit includes 4 crates, 4 pallets and several long and short pieces of lumber.



62232 Track Inspection Shed

In order to provide track inspection cars with shelter, many railroad companies built small sheds. The old fashioned roof, planked walls, double doors and the small side entrance have been weathered. The gate opens and closes automatically.

Note: Kit includes a corrugated metal-style roof instead of a shingled roof.

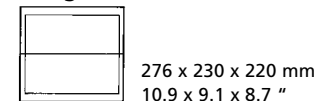

62209 "Grizzly Flats" Station

The American Victorian style station is typical for the time around 1870. The doors and windows can be opened and closed. We recommend the baseplates #62005 to enhance the model (1 set).



485 x 310 x 290 mm
19.1 x 12.2 x 11.4 "



#62209 Rear View "Grizzly Flats" Station

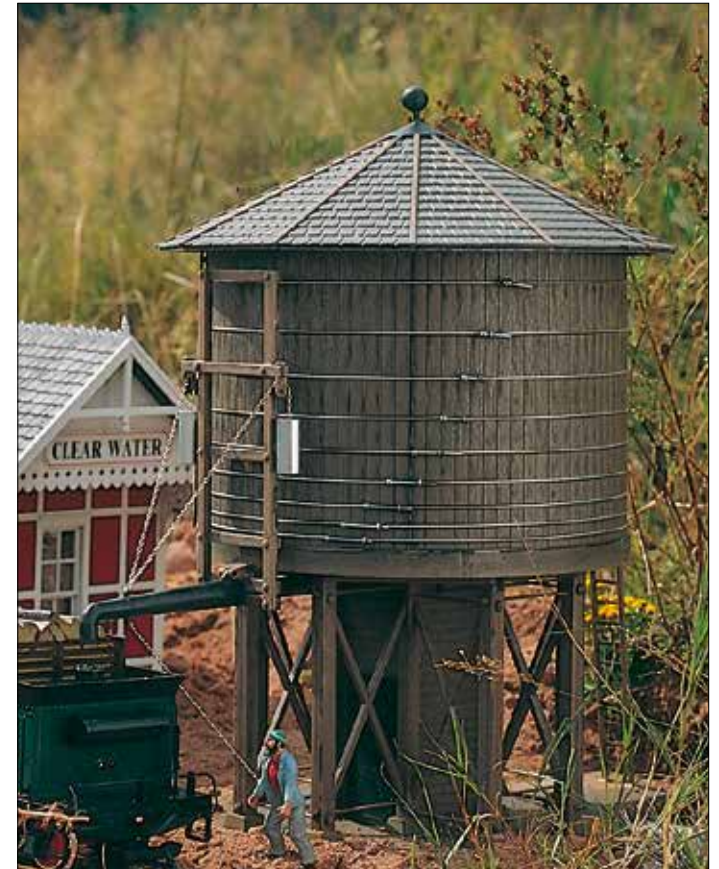
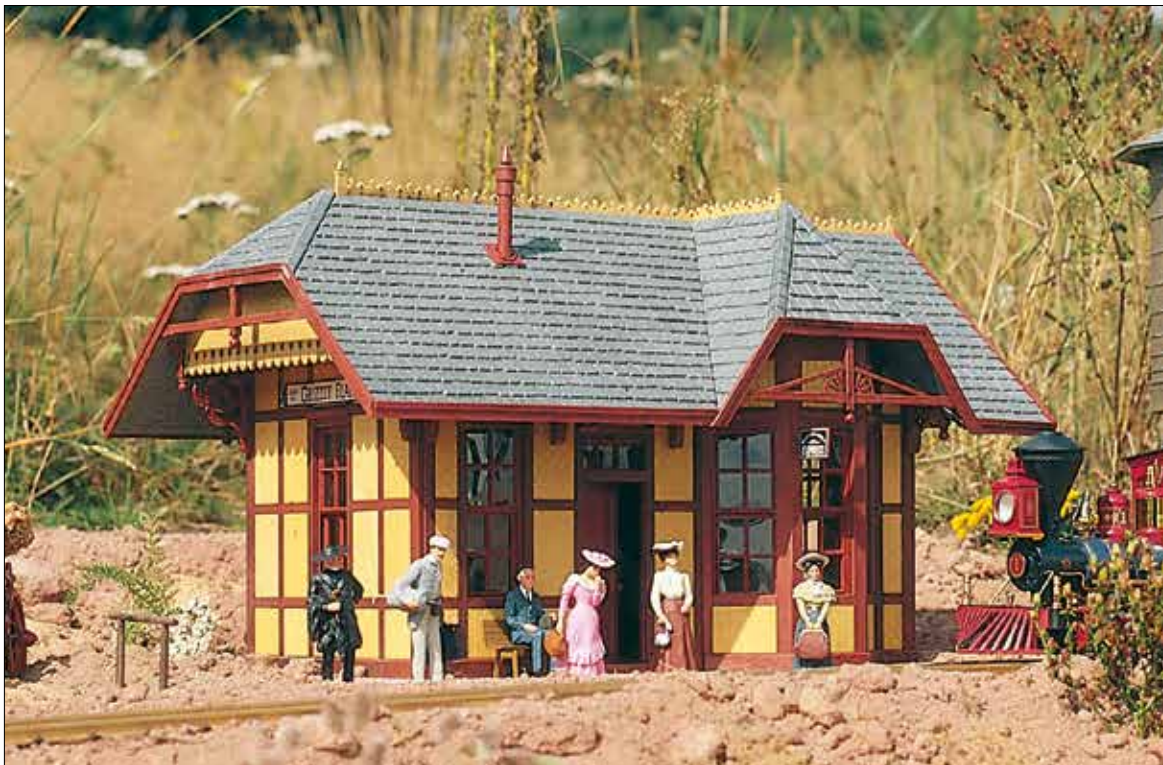

62210 "Rio Grande" Water Tower

The artificially aged and weather-resistant kit is an original reproduction of a 50,000 gallon tank used by the Rio Grande Southern in Rico, CO. It is the prototype for all RGS & Denver & Rio Grande water tanks. The tank can be filled with water and emptied via the spout. Baseplate included.

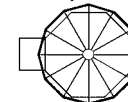

252 x 335 x 450 mm
9.9 x 13.2 x 17.7 "



62230 "Clear Water" Station

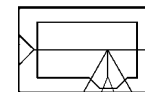

485 x 310 x 290 mm
19.1 x 12.2 x 11.4 "

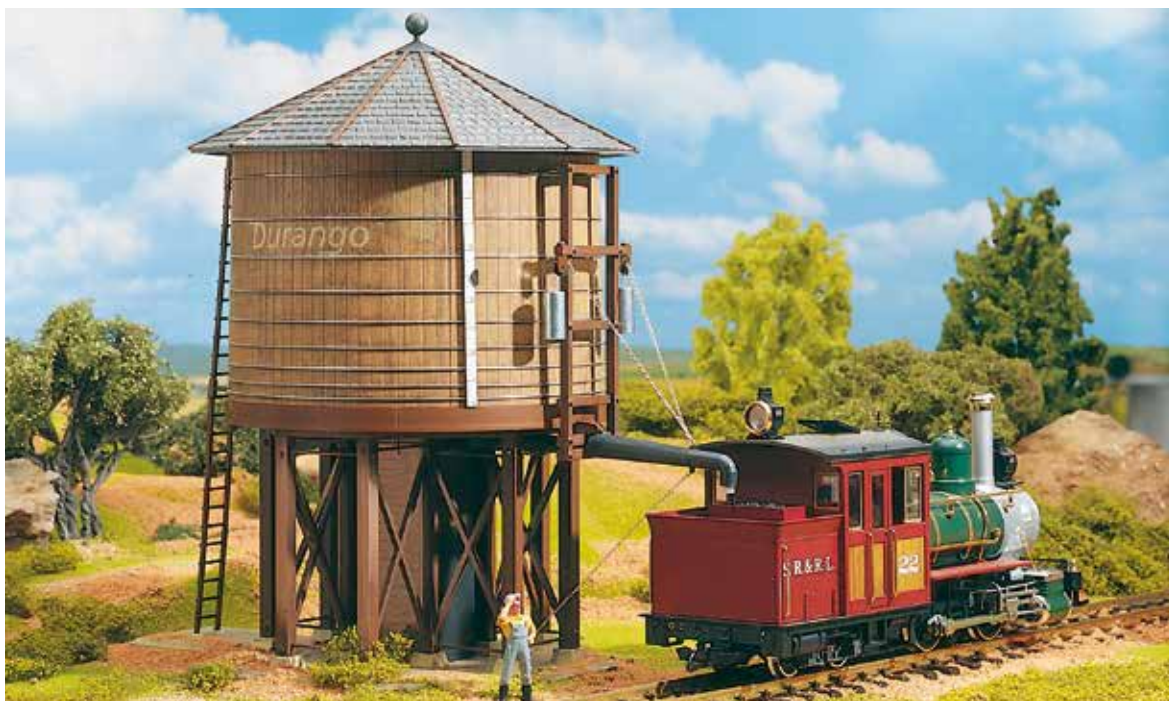

62231 "Durango" Water Tower

The tank can be filled with water and emptied via the spout. Baseplate included.

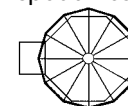

252 x 335 x 450 mm
9.9 x 13.2 x 17.7 "

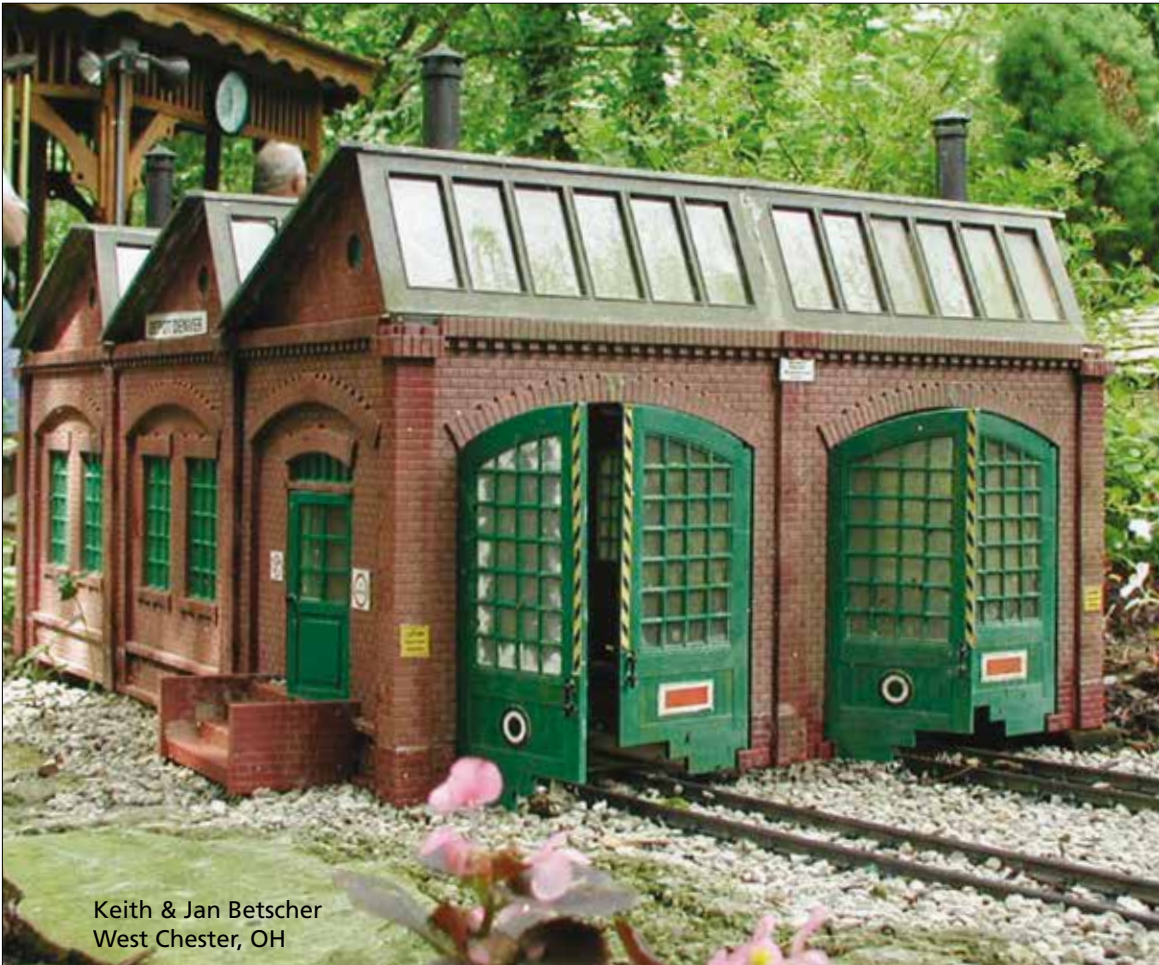

Keith & Jan Betscher
West Chester, OH

62001 "Sonneberg" Loco Shed

With the PIKO automatic door closer, #62002 the doors can be opened and closed automatically by a locomotive moving in or out. The shed accommodates locomotives of up to 25.6" in length. The realistically aged and weather-resistant building can be extended in length as well as in width by adding extension kits.

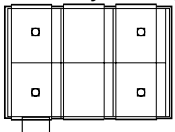

526 x 705 x 370 mm
20.7 x 27.8 x 14.6 "
Track Centers 230 mm



62007 Loco Shed Extension Set

With this extension set the Sonneberg Loco Shed, #62001, can be extended by 9.1" (23cm). The set contains all necessary parts as well as the proper extension for the Automatic Door Closer, # 62002.
230 x 526 x 370 mm
9.1 x 20.7 x 14.6 "

62002 Automatic Door Closer

Once the Automatic Door Closer is added to the Sonneberg Loco Shed #62001 the doors will be opened and closed automatically by a locomotive moving in or out. Due to its modular design the Automatic Door Closer can be used with extended loco sheds.

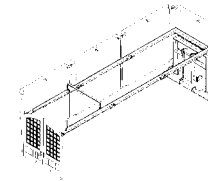

1138 x 174 x 10 mm
44.5 x 6.9 x 0.4 "



62056 Schwarz's Coal Supply

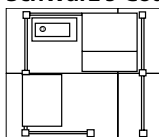

634 x 534 x 220 mm
24.9 x 21.0 x 9.1 "



62261 Log Cabins

Two small log cabins with opening doors.

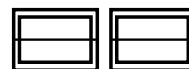

90 x 130 x 120 mm
3.6 x 5.1 x 4.7 "



62044 Red River Loco-shed

Engine shed with two-wing door. Doors open and close automatically as the locomotive enters or leaves.

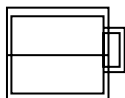

316 x 230 x 220 mm
12.4 x 9.1 x 8.7 "



62077 Loading Crane

Small hand-operated loading crane. The kit includes several crates and pallets.

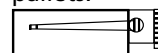

335 x 145 x 60 mm
13.2 x 5.7 x 2.4 "



62059 St. Ursula Church

The lovely St. Ursula's church is scenically situated in the cozy Fex Valley of Switzerland. The interior is adorned with marvelous 16th century frescoes. The model comes complete with a bell and an opening front door.

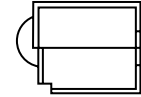

300 x 200 x 350 mm
11.8 x 7.9 x 13.8 "



62109 Saint Bonifaz Chapel

This beautiful little chapel overlooks the town. The bell rings at regular intervals to welcome the townspeople through the model's opening doors. We recommend the set of baseplates #62005 to enhance the model further (1 set).

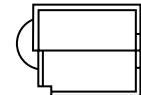

300 x 200 x 350 mm
11.8 x 7.9 x 13.8 "



62228 "Red River" Station

This realistically weathered building can be easily disassembled and is equipped with opening doors. We recommend the set of baseplates #62005 to enhance the model (1set).

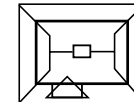

215 x 175 x 205 mm
8.5 x 6.9 x 8.1 "



62021 "Fred's" Snack Bar

The kiosk is realistically weathered and weather proof. Various accessories such as flags and newspaper stands are included to complement the kiosk. We recommend the baseplates #62005 to enhance the model (1 set).

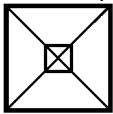

150 x 150 x 170 mm
4.9 x 4.9 x 5.9 "



62285 Set of 5 Garden seats



62043 "Tiefenbach" Station

Somewhat off the beaten path but still close by is the station "Tiefenbach". With its pleasant warm colors and attractive shutters, the station adds a touch of romance to the garden railway. In addition to the ticket hall, the three-part building houses a busy station restaurant. The doors can be opened and closed. To complete the set we recommend the baseplates #62005 (2 sets).

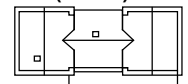

610 x 240 x 240 mm
24.0 x 9.4 x 9.4 "



The Southwest Series offers a number of typical Southwest adobe-style buildings. Earth tone colors fit well with the sun-drenched landscape. A characteristic feature of these buildings are the exposed ends of the round wooden beams that support the flat roof.

62254 Las Cruces Town Building

③

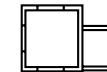

290 x 200 x 180 mm
11.4 x 7.9 x 7.1 "

62253 Las Cruces Church

①

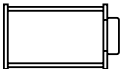

390 x 220 x 330 mm
15.3 x 8.7 x 13.0 "

62252 Las Cruces Train Station

②

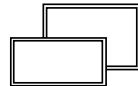

490 x 310 x 240 mm
19.3 x 12.2 x 9.4 "

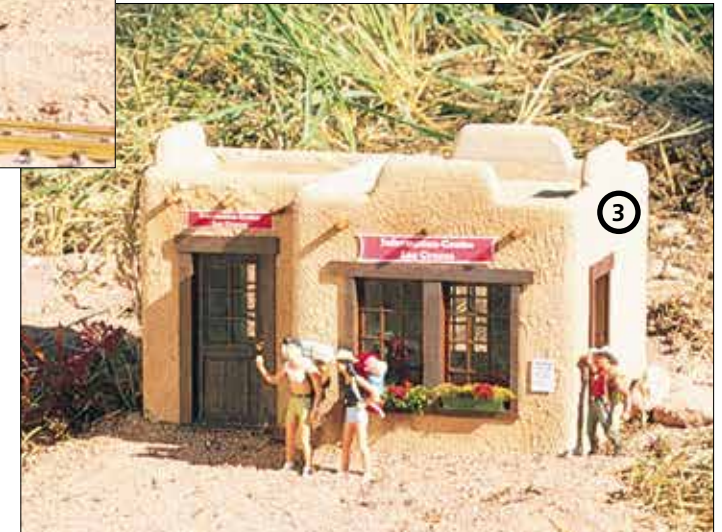

③



62106 Santa Fe Medical Center

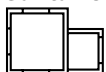

290 x 200 x 180 mm
11.4 x 7.9 x 7.1 "



62105 Santa Fe Station

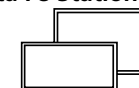

490 x 310 x 240 mm
19.3 x 12.2 x 9.4 "



62108 Mission San Antonio

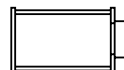

390 x 220 x 330 mm
15.3 x 8.7 x 13.0 "



62014 Brewery Main Section

① You can create a unique brewery complex by combining multiple kits or by adding side buildings. The building sections are weather-resistant and realistically aged. The gate at the main entrance can be opened and closed.



704 x 280 x 500 mm
27.7 x 11.0 x 19.7 "



62289 Factory Gate

② Our big factory gate with its iron doors fits perfectly to the Factory Walls (#62288) and creates an attractive entrance to each industrial setting.

 240 x 42 x 220 mm
10.9 x 9.1 x 8.7 "

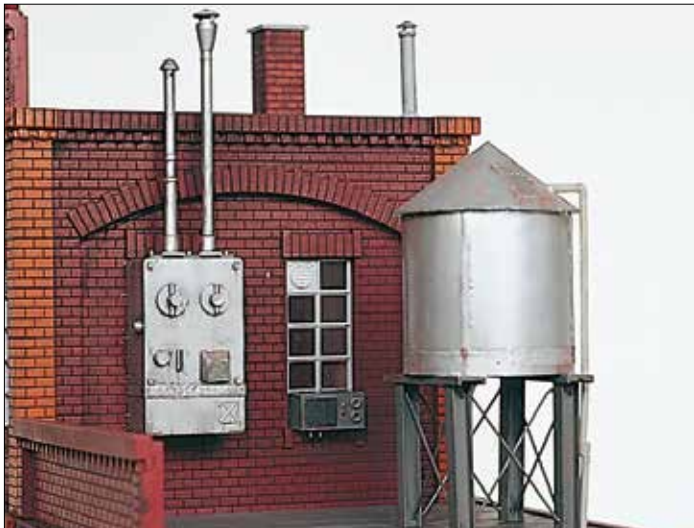

62013 Brewery Equipment

⑦ This accessory kit consists of an airconditioning unit, a ventilation unit and a large tank that stores water for the brewery's sprinkler system. The water tank is a common sight in America.



62015 Brewery Sidebuilding

③ The distinctly shaped roof with the sloping roof windows makes this building particularly interesting. The front gates of this weather-resistant, realistically aged model open.

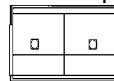

480 x 250 x 297 mm
18.9 x 9.9 x 11.7 "

62016 Chimney

⑤ The matching chimney for our brewery complex takes its stability from its solid base. The chimney itself stands 28.7" tall. A billboard can be attached to the outside.



160 x 160 x 730 mm
6.3 x 6.3 x 28.7

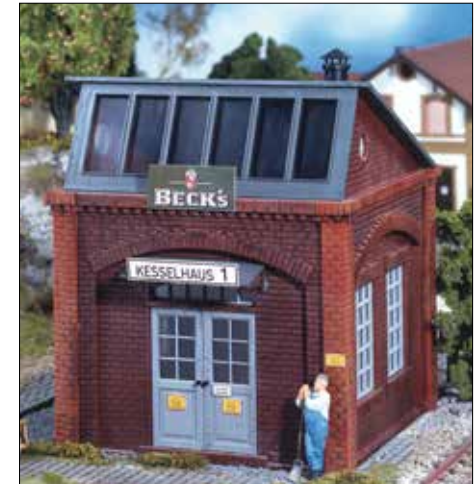

62017 Boilerhouse

④ The boilerhouse with its shed roof and opening door can also be used as a machine shop or warehouse. Due to its modular construction the building can be extended as needed.



250 x 280 x 297 mm
9.8 x 11.0 x 11.7 "

62288 Brick Factory Walls

⑥ Industrial complexes are often surrounded by brick walls. The enclosed walls and pillars have an overall length of 41.1". They are an excellent fit for PIKO's Brewery #62014 or many other industrial buildings. They can be used with the #62289 factory gate.

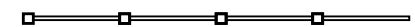

105 x 3,3 x 8,7 cm
41.1 x 1.3 x 3.4 "



62290 Industrial Fence

④ Two sets #62290 are required for completely fencing the depot.

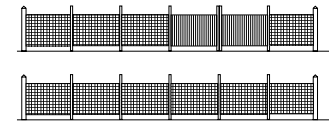

Content: 1 gate, pales, app. 4.6 ft. fence

62038 Tank (high)

① Tank, hoch / high:
 ø 315 mm
 370 mm hoch / high
 ø 12.4" x 14.6"

62039 Tank (low)

② Tank, niedrig / low:
 ø 315 mm
 270 mm hoch / high
 ø 12.4" x 10.6"

62037 Depot Office

③  240 x 230 x 200 mm
 9.5 x 9.0 x 7.9 "

The two diesel tanks are fitted with a railing on top, a fixed ladder to reach the top and a fill pipe. „Exxon“ and „Esso“ stickers for branding the depot are included in the kit. If necessary the tanks can be put on #62005 baseplates.

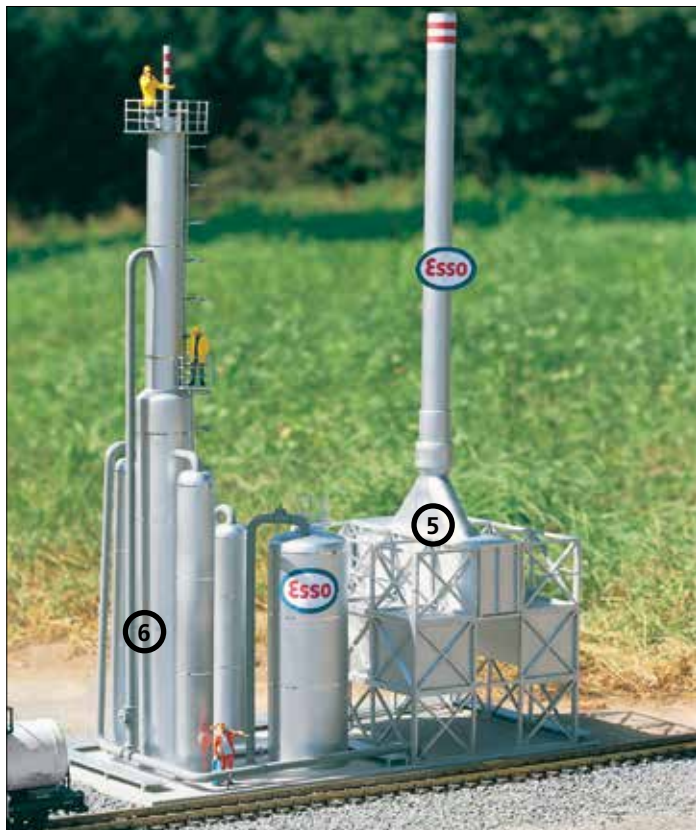

62046 Refinery Burn-Off Plant

⑤

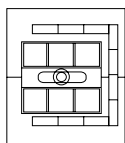

460 x 534 x 1060 mm
18.1 x 21.0 x 41.7 "

62047 Refinery Cracking Plant

⑥

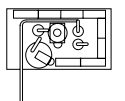

460 x 267 x 1010 mm
18.1 x 10.5 x 39.8 "



62049 Refinery Loading Dock

⑦

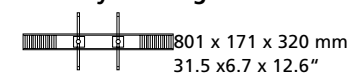

801 x 171 x 320 mm
31.5 x 6.7 x 12.6 "



62048 Refinery Storage Tanks

⑧

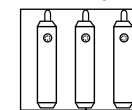

3 tanks included.
267 x 348 x 90 mm
10.5 x 13.7 x 3.6 "
1 tank:
250 x 52 x 80 mm
9.8 x 2.0 x 3.2 "

62019 Mr. Mann's Can Factory

The weather-resistant and realistically aged building is modeled after early 20th century industrial buildings. The doors on this kit can be opened and closed. Thanks to the kit's modular design, several kits can be combined to create an even larger factory building. The factory's exterior color makes it the perfect fit for the Power Substation #62018. The water reservoir and air conditioning unit shown here are from kit #62013 and are not included. We recommend the baseplates #62005 to enhance the model (1 set).

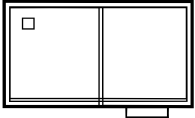

470 x 280 x 500 mm
18.6 x 11.0 x 19.7 "

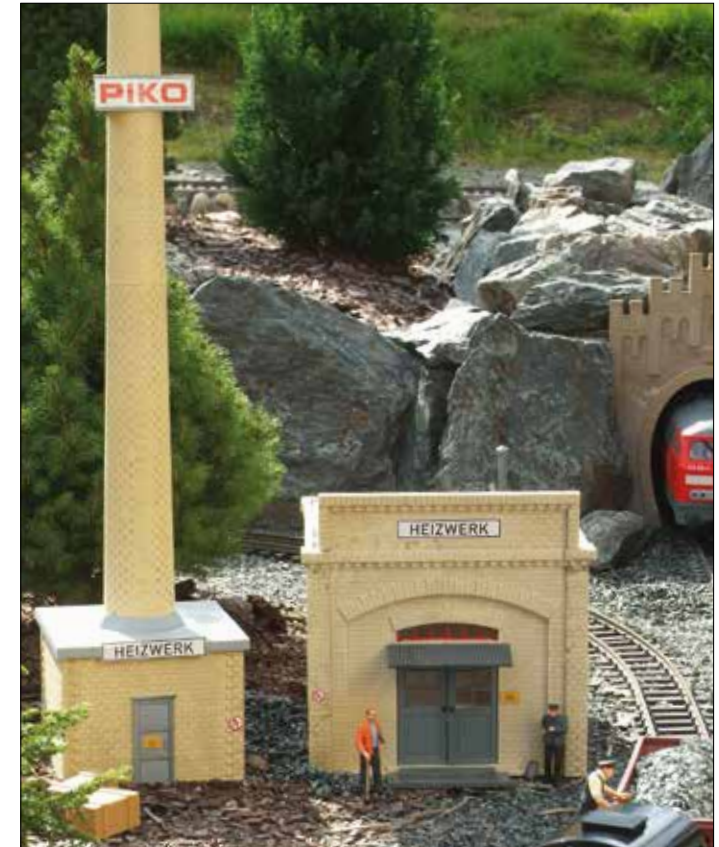
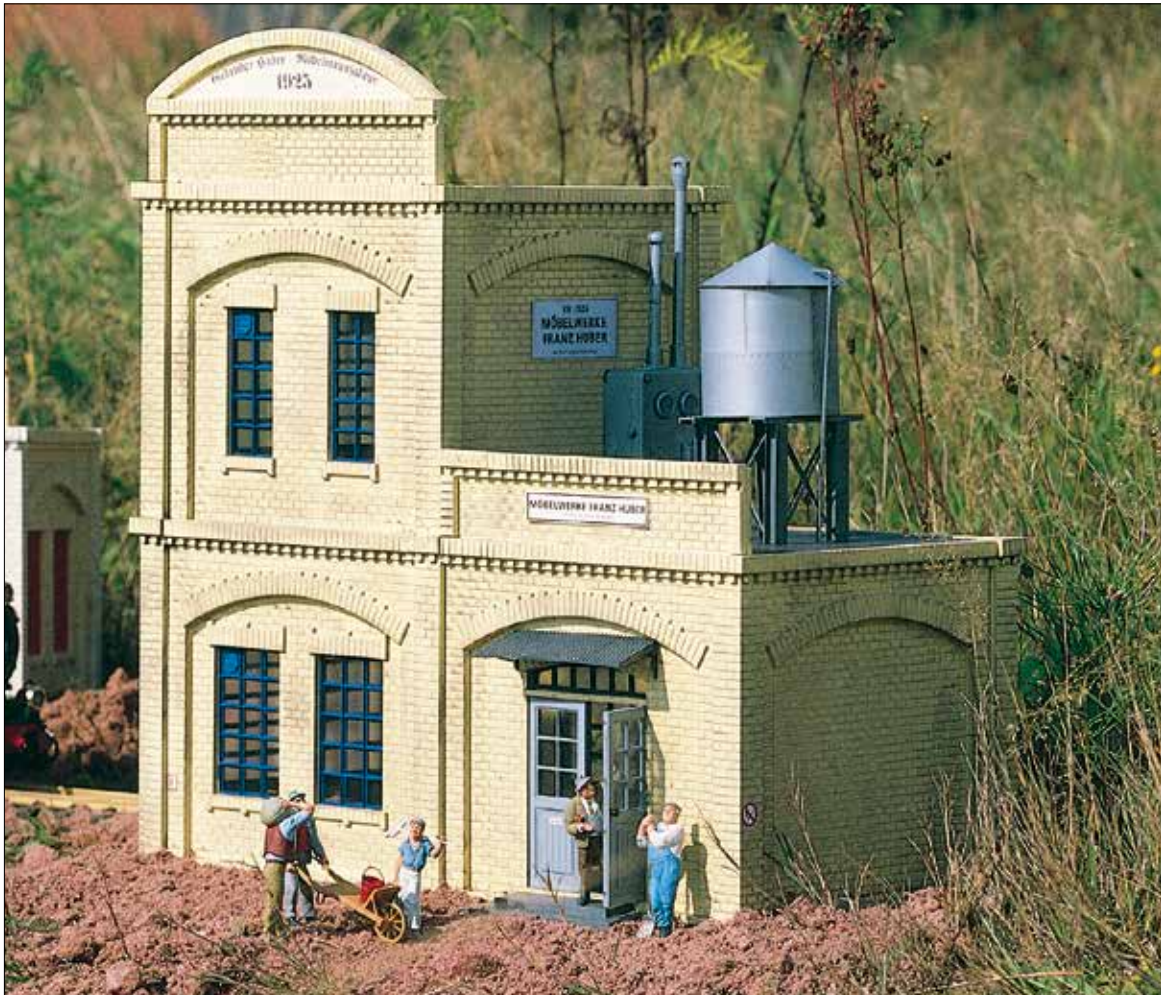

62018 Power Substation



Chimney: 6.3 x 6.3 x 28.7 "

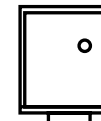

Power Station: 9.8 x 11.0 x 11.7 "



62011 Automatic Loader for Gravel Works

- ① Place the gravel in the main building's #62009 gravel container. From there it can be loaded into railcars by using the motor driven automatic loading unit. (not visible in this photo)

62009 Gravel Works Main Building

- ③ The gravel work's main building stands on a masonry base with windows. The loading and unloading can be monitored from the small annex. The main building can be extended with the Side Building #62010, and the Automatic Loader #62011, to enable realistic operation.

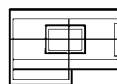

500 x 200 x 515 mm
19.7 x 7.9 x 20.3 "

62010 Gravel Works Side Building

- ② This addition simulates a housing for a conveyer to lift gravel up to the main building.

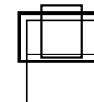

225 x 270 x 370 mm
8.8 x 10.6 x 14.6 "



62034 Co-Op Warehouse

① The building can be set up on its own or in conjunction with the storage tower #62035. We recommend the baseplates #62005 to enhance the model (1 set).

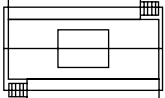

526 x 280 x 330 mm
20.7 x 11.1 x 13.0 "

62035 BayWa Storage tower

② Besides the "BayWa" decals the kit includes decals to create a "Raiffeisen" building. The building can be set up on its own or in conjunction with the warehouse #62034. We recommend the set of baseplates #62005 to enhance the model (1 set).

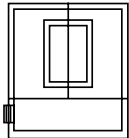

360 x 310 x 800 mm
14.2 x 12.2 x 31.5"





62036 Co-Op Silo

The kit contains one silo and the necessary piping.

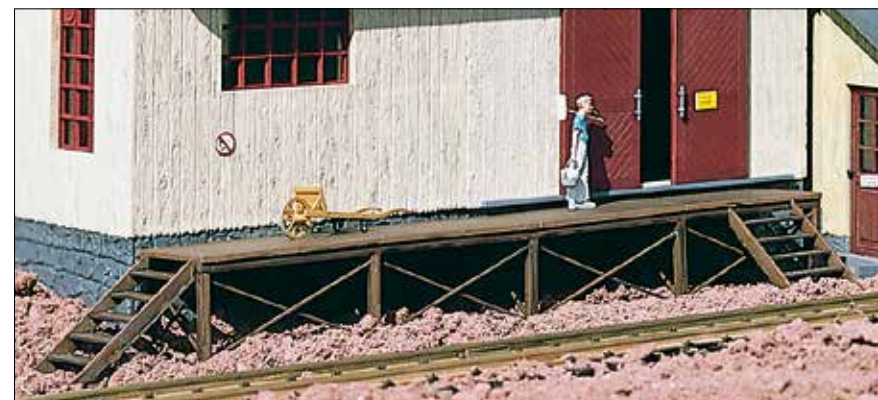
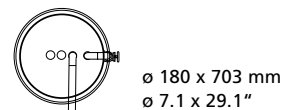

62287 Loading Dock for Goods Shed

2 sets of stairs and 4 platform sections.

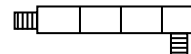

$515 \times 145 \times 60 \text{ mm}$
 $20.3 \times 5.7 \times 2.4''$



62064 Gramss Baker's Shop

①

62065 Bauer's Florist's Shop

②

62066 Dr. Lang's Practice

③

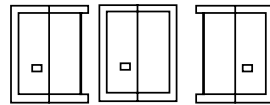

Size for:
#62064, #62065, #62066:
160 x 210 x 285 mm
6.3 x 8.3 x 11.2 "

Size for:
#62067, #62068:
160 x 210 x 320 mm
6.3 x 8.3 x 12.6 "

Garden Town Series

The buildings in the Garden Town Series with their lovingly designed details can be used either as single units or in conjunction with each other to create the idyllic atmosphere of a small town or a particular street. With the exception of a few individual parts the buildings can be assembled without glue.



62068 Gunilla's Hair Salon

④

62067 Sunny Pharmacy

⑤





62057 Beate's Pottery

This lovingly detailed home is accompanied by a market stand stocked with pieces of pottery. The front door can be opened and closed. We recommend the set of baseplates #62005 to enhance the model (1 set).



240 x 290 x 250 mm
9.4 x 11.4 x 9.8 "



62053 Frank's Timbered House

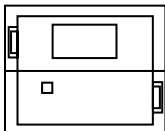

360 x 290 x 345 mm
14.2 x 11.4 x 13.6 "



62050 Dr. König's House

Dr. König and his family live in this little half-timbered home with hipped roof. Many accessories such as flower boxes and the newspaper holder, as well as the detailing on the building, make this home a showpiece for any layout. The front door can be opened.

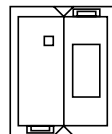

360 x 290 x 345 mm
14.2 x 11.4 x 13.6 "

We recommend the set of baseplates #62005 to enhance the model (1 set).



62051 Rosenbach Watermill

Decorative timberwork and a hipped roof make the old watermill with its fully operational water wheel an idyllic sight on your garden layout. The building has two opening doors and many accessories such as window boxes and a newspaper holder as well as many other details. The water wheel can be motor-driven. We recommend the Water Wheel Motor #62052.

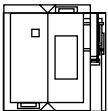

326 x 345 x 370 mm
12.8 x 13.6 x 14.6 "

62052 Water Wheel Motor

In case the water wheel on your layout cannot be driven by running water, this robust electric motor can drive the water wheel. The kit includes the motor itself as well as all necessary parts for its installation.



62022 Beer Garden Café

With its bright attractive colors, pretty flower boxes, maypole, tables, and benches in the idyllic garden, the Beer Garden Cafe invites customers to linger. A scene which forms a romantic feature on any layout. The doors of the weather-resistant and partially aged model open. Benches and picnic tables are included in this kit.

We recommend the set of baseplates #62005 to enhance the model (1 set).

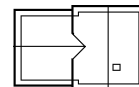

370 x 240 x 240 mm
14.6 x 9.4 x 9.4 "

62282 Beer Garden Tables and Benches

This kit can be used to extend the beer garden of the „Beer Garden Café“ #62022 or any other garden as desired. The kit includes three tables, six benches and three garden seats.



62072 House under construction

Some of the walls have already been repainted as can be seen by the difference in color. The weather resistant kit includes scaffolding and fence sections. The doors can be opened and closed.

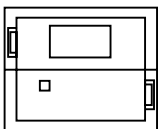

360 x 290 x 345 mm
14.2 x 11.4 x 13.6 "

We recommend the set of baseplates #62005 to enhance the model (1 set).



62073 Brenda's Brick House

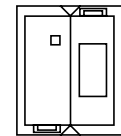

360 x 290 x 345 mm
14.2 x 11.4 x 13.6 "



62058 Old Mill

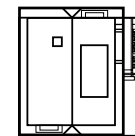

326 x 345 x 370 mm
12.8 x 13.6 x 14.6 "

Water mill motor #62052 on page 148



62117 Fresh Produce Stand

①

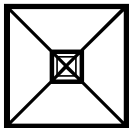

150 x 150 x 182 mm
4.9 x 4.9 x 7.4"

62118 Sausage Shop

②

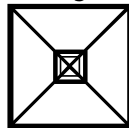

150 x 150 x 182 mm
4.9 x 4.9 x 7.4"

62119 Cheese Shop

③

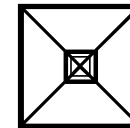

150 x 150 x 182 mm
4.9 x 4.9 x 7.4"

The weekly farmers market has a number of small booths where people buy produce and other groceries. (Figures and accessories not included.)
The doors of the weathered booths can be opened and closed.



62293 Work Shop Accessory Set



62294 Softdrink Crates



62284 Old-fashioned Petrol Pump, Yellow (Not Shown)
The ready-made kit includes a radiator water can, tire racks and replacement tires.



62286 Antique Gasoline Pump "Texaco"
1 Addition to #62264. The ready-made kit includes a radiator water can, tire racks and replacement tires.

62264 "Texaco" Gas Station

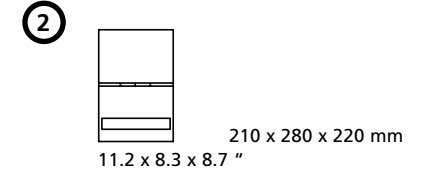

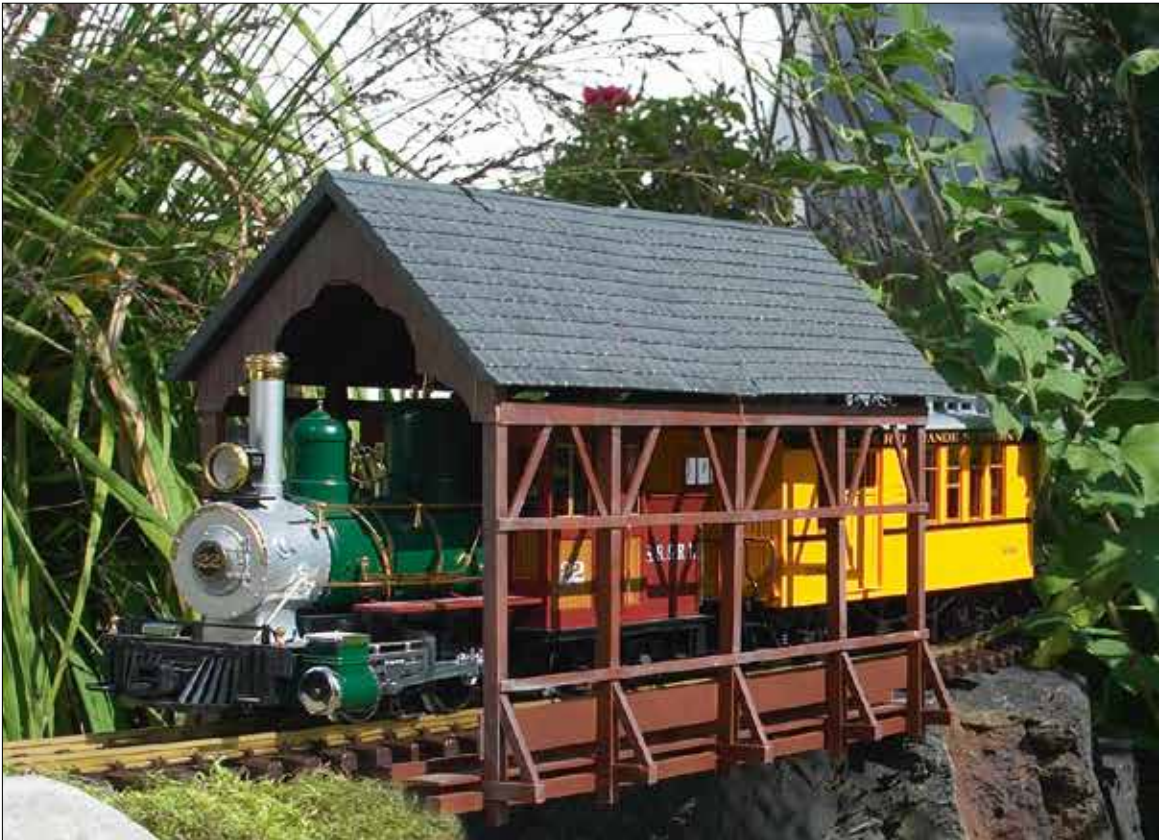

62116 Covered Bridge

The classic covered bridge is a well-known symbol of days gone by in America. This PIKO model captures all the charm of the original. The bridge deck is ready for easy installation of your track.
 Note: Check vertical clearance of rolling stock before assembling the bridge.

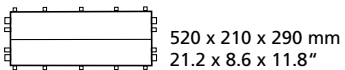

Kiosk
 150 x 150 x 170 mm
 5.9 x 5.9 x 6.7 "

Teepee
 190 x 190 x 300 mm
 7.7 x 7.7 x 12.2 "

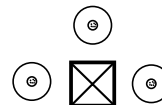

62111 Trading Post

The trading post and three teepees form quite a tourist attraction. Locally made jewelry and souvenirs are offered here. The door can be opened and closed. Teepees pictured below





62104 Dr. Reynolds Country Home

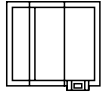

280 x 260 x 230 mm
11.0 x 10.2 x 9.1 "

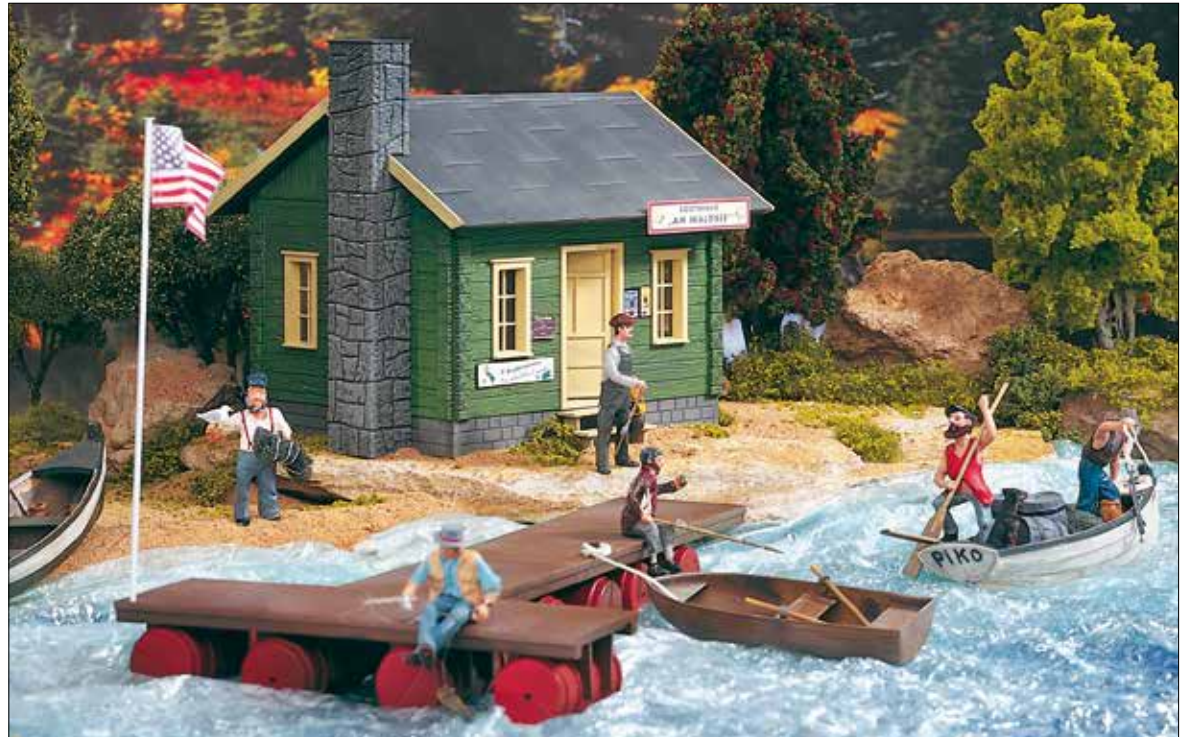

62103 Bait & Tackle Shop

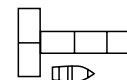

House:
254 x 230 x 230 mm
10.0 x 9.1 x 9.1 "



Pontoon Dock:
400 x 220 x 45 mm
15.7 x 8.7 x 1.8 "

62283 Rowing Boat

The little boat is a perfect addition to the "Bait & Tackle Shop" kit #62103. Color may vary from photo.



62012 Gazebo

The gazebo's roof is supported by 12 columns. Flower-pots and flower material for the pots are included. The gazebo is weather-resistant and is a great attraction on any layout.



270 x 270 x 250 mm
10.6 x 10.6 x 9.8 "



62242 Fire-Department No. 6

The fire station can often be found near the railroad station. With its two large moveable doors, windows with gratings and the sturdy stone surfacing, the building provides sufficient space for the firefighters and the fire engine.

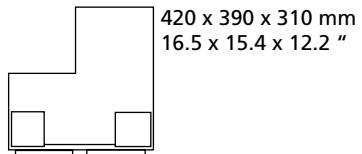

420 x 390 x 310 mm
16.5 x 15.4 x 12.2 "



62251 Filling Station

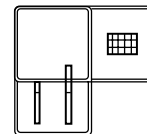

420 x 390 x 310 mm
16.5 x 15.4 x 12.2 "



62120 White Barn

Once a common sight along American highways and byways, barns – and their roofs – were used to advertise many things, such as fireworks for sale at the next exit.

The doors of the barn open. The kit includes two different style roofs and signs in English as well as in German.

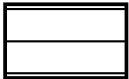

260 x 400 x 280 mm
10.2 x 15.7 x 11.0 "



62110 Red Barn



400 x 400 x 280 mm
15.7 x 15.7 x 11.0 "



62291 White Wooden Fence

The white wooden fence is 63" (160 cm) long. It can be arranged in a straight line or around a yard with 90° corners.



Original Layout: Ron Gibson

62222 Fire Post

Lookouts like this are used throughout North America to monitor forests for wildfires. The observation platform sits atop a finely detailed timber frame with integrated wooden staircase. The Fire Post is weather-resistant and realistically aged.



220 x 220 x 720 mm
8.7 x 8.7 x 28.3 "



62112 Old Fallsington Feed and Seed Company

Henry Fallsington prefers to take life easy, sitting back in his rocking chair rather than loading railroad cars spotted at the elevated platform or working in the office of his little warehouse. (Rocking chair #62295 not included) The door of this aged model can be opened and closed.

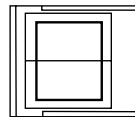

Platform:
340 x 285 x 225/170/125 mm
13.9 x 11.6 x 9.2/6.9/5.1 "
Building:
240 x 230 x 175 mm
9.8 x 9.4 x 7.1 "

62295 Rocking Chairs (Set of 2)

There's nothing like leaning back in a comfortable old rocking chair. Your G-Scale figures will enjoy a relaxing break on a patio or porch. (Figures not included)



62262 Brad's fishing cabin

Brad built his cabin over the lake to be closer to the water. He stores his fishing rods inside the little cabin with opening doors. During weekends he enjoys the peace and quiet.

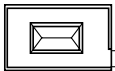

410 x 210 x 180 mm
16.2 x 8.3 x 7.1 "



62054 German Embassy

The German Embassy is situated in an old empire style building with red bricks, slate roof and sand stone window sills. The two opening doors with their small porches, the bay windows and the decorated window sills make the building stand out. The distinctive building fits in no matter what the theme of your layout is. We recommend the baseplates #62005 to enhance the model (1 set).

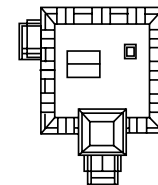

450 x 370 x 505 mm
17.7 x 14.6 x 19.9 "

62223 "Black Hill" Saloon

With the functional swing door and large balcony, that stretches across the entire front, the building is a typical US-Western-Saloon. The weather-resistant building has been realistically weathered.



400 x 300 x 360 mm
15.7 x 11.8 x 14.2 "



62224 Pony Express Cabin

①

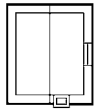

254 x 230 x 230 mm
10.0 x 9.1 x 9.1 "

62225 City Sheriff

②

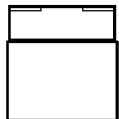

220 x 224 x 210 mm
8.7 x 8.8 x 8.3 "



We recommend the set of baseplates #62005 to enhance the model (1 set).



62246 Outhouse

The outhouse was once a quite common necessity. This kit is a realistic model of a typical outhouse. The door with the customary heart shaped window opens.

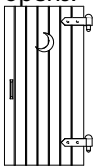

The kit includes a second door with a half moon window for the US.



60 x 70 x 110 mm
2.4 x 2.8 x 4.3 "



62247 Stable

The small ranch stable finds room next to almost any country home. It can easily house a horse or a cow while the back has room to store a small tractor or a car.

We recommend the baseplates #62005 to enhance the model (1 set).

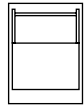

340 x 250 x 135 mm
13.4 x 9.8 x 5.3 "

62229 Country Church

This attractive church with its picturesque little bell tower and porch is an ideal addition to Sam's and Aunt Bea's home. The weather-resistant and slightly weathered model creates a truly American atmosphere. The doors can be opened and closed. We recommend the baseplates #62005 to enhance the model (1 set).

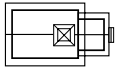

150 x 315 x 360 mm
5.9 x 12.4 x 14.2 "





62221 "Aunt Bea's" Farmhouse



250 x 350 x 315 mm
9.9 x 13.8 x 12.4 "



62249 Cousin Jane's Farmhouse

Typical US-style country home with front porch. The weather-resistant kit is partially aged and has opening doors.

We recommend the set of baseplates #62005 to enhance the model (1 set).



300 x 210 x 235 mm
11.8 x 8.2 x 9.3 "

62248 Grandpa's Farmhouse

This traditional home is built in typical American wood-sided style. Homes like it can be found all across the United States. The doors of the weather-resistant and partially aged model can be opened and closed. We recommend the baseplates #62005 to enhance the model (1 set).



250 x 350 x 315 mm
9.9 x 13.8 x 12.4 "



62226 "Sam's" House



300 x 210 x 235 mm
11.8 x 8.2 x 9.3 "



62208 "Bill's" Body Shop

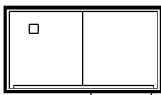

510 x 250 x 260 mm
22.4 x 9.8 x 10.2 "

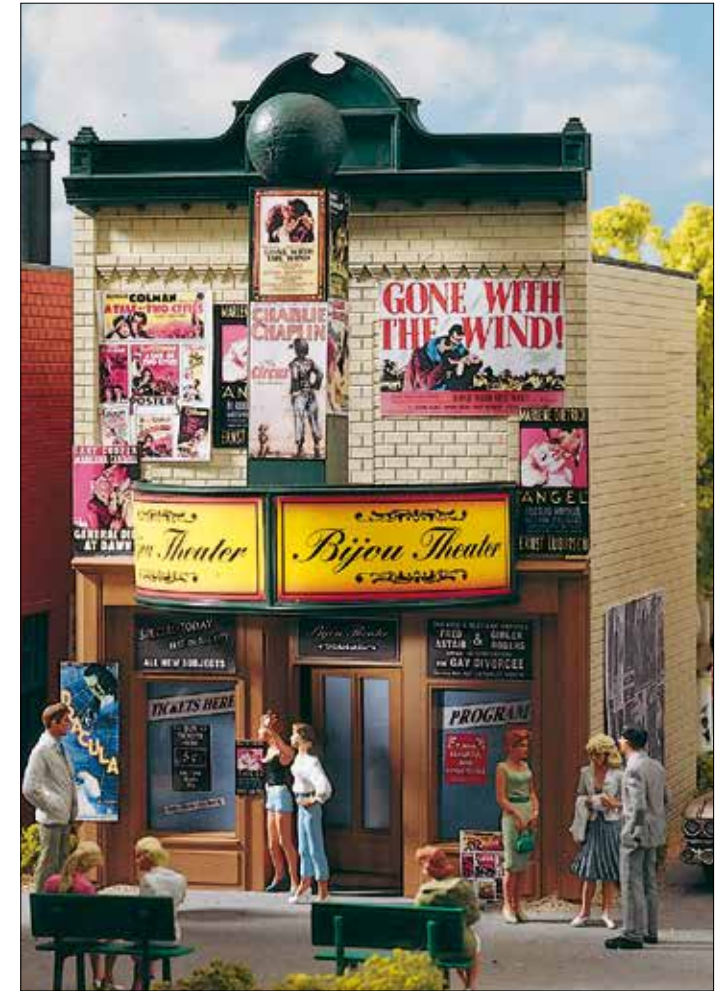

62233 Bijou Theater

Many old movie posters and ads recreate the typical cinema of the thirties. The doors of this weather-resistant and partially aged building can be opened and closed.

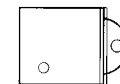

360 x 290 x 345 mm
14.2 x 11.4 x 13.6 "

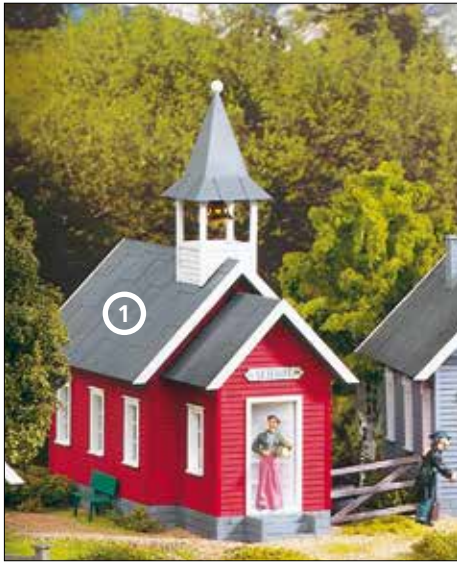

62243 Little Red School House
 ① The attractive little bell tower housing the brass school bell and the strong dark red exterior paint make the building the focal point of any rural garden railroad scene. The door can be opened.

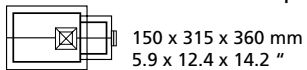

Gingerbread Series



62238 R. King's House (mint green)

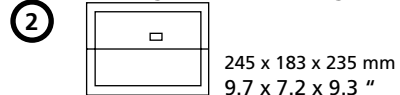

62240 M. Lewis' House (lavender)

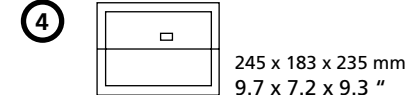

62239 B. Adams' House (yellow)

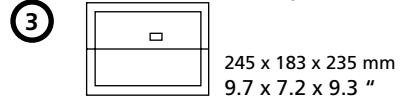

62256 Craft Shop

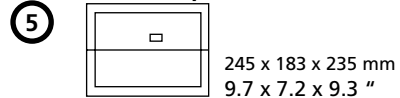



62028 Union Station

The Union Station has platform roofs on each end of the building. A working PIKO clock adorns the front of the building. The station doors open. Benches are included in this kit.

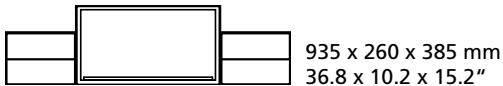

62114 White Knight Hamburgers

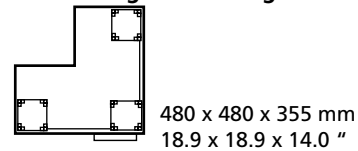

62078 Mel's Fix-it Shop

Modest but sturdy brick home with attached storage shed for ladders and equipment. The doors of this model can be opened. The scaffolding is included.

We recommend the baseplates #62005 to enhance the model (1 set).

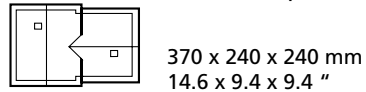



62259 Peter's Motorcycle Maintenance Shop

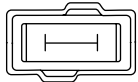

374 x 190 x 225 mm
14.7 x 7.5 x 8.9 "



62258 Dora's Bakery Shop

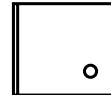

220 x 240 x 305 mm
8.7 x 9.4 x 12.0 "

62257 Farmer's State Bank



220 x 240 x 305 mm
8.7 x 9.4 x 12.0 "

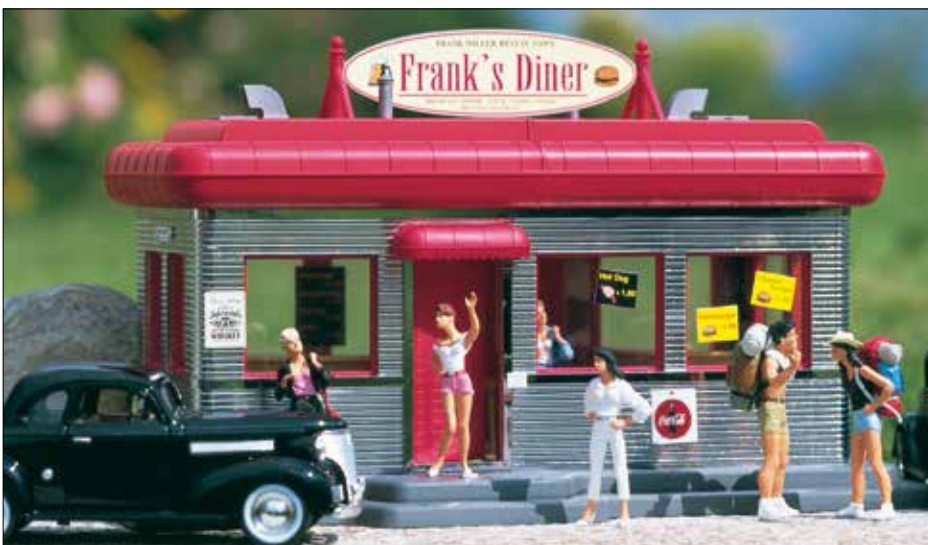

62250 Downtown Diner

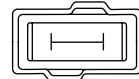

374 x 190 x 225 mm
14.7 x 7.5 x 8.9 "

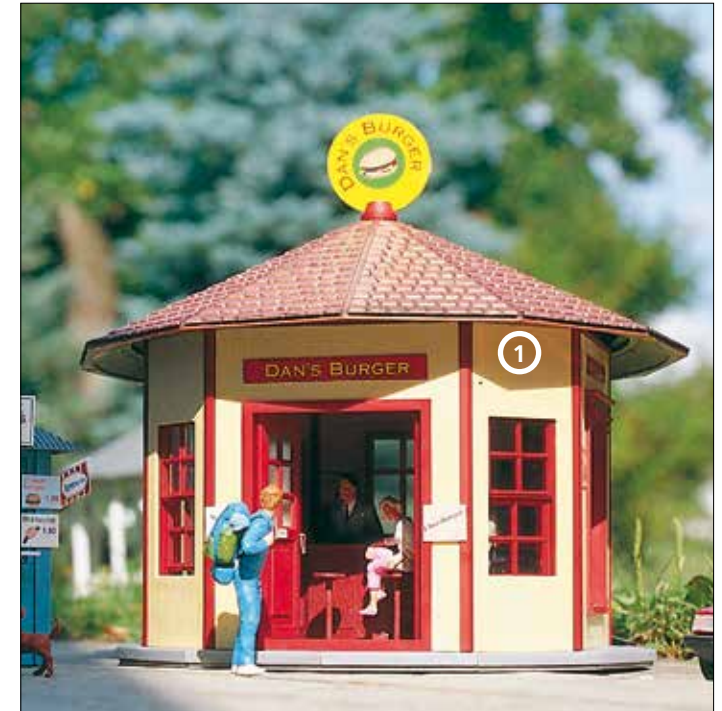

62227 „Dan's“ Burger

①



270 x 270 x 253 mm
10.6 x 10.6 x 10.0 "

62266 Michael's Emporium

②



220 x 240 x 460 mm
8.7 x 9.4 x 18.1 "

62267 Hudson's Home Goods

③



220 x 240 x 430 mm
8.7 x 9.4 x 16,9 "



62219 "David's" Barber Shop

④

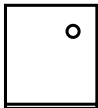

220 x 240 x 305 mm
8.7 x 9.4 x 12.0 "

62204 "Jenny's" Clothing

⑥

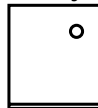

220 x 240 x 345 mm
8.7 x 9.4 x 13.6 "

62220 "Paul's" Dry Goods

⑤

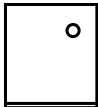

220 x 240 x 305 mm
8.7 x 9.4 x 12.0 "

62207 "Dr. Goldstein's" Pharmacy

⑦

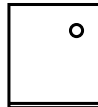

220 x 243 x 330 mm
8.7 x 9.6 x 13.0 "

Buildings such as this two-story brick store were built around the turn of the 20th century and to this day can be found all across North America. The typical sliding windows and the doors open. The kit is weather-resistant and partially aged

We recommend the set of wooden sidewalks #62281.



62023 The Mansion

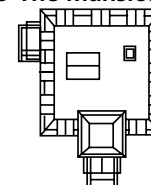

450 x 370 x 505 mm
17.7 x 14.6 x 19.9 "



From an original model designed by Andrew de Lucia, El Dorado Hills, CA

62260 California Hotel

The guests reach the hotel's upper floors via outside stairways that give the building its distinctive look. Built in the architectural style of the early 20th century this hotel is suitable for many types of Western style layouts.

The kit includes base plates.

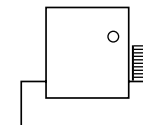

370 x 320 x 450 mm
14.6 x 12.6 x 17.7 "

PLEASANTOWN COLLECTION

The Pleasantown Collection Buildings can be assembled and disassembled easily due to their unique "pin" connector system.

62236 A.C.M.E. Hardware Store

①

62237 Leather Goods & Boots

②

62235 A.C.M.E. Liquor Store

③

62234 General Store

④

62218 Saloon

⑤

62217 Dentist

⑥

62215 White Schoolhouse

⑦

62216 Sheriff's Office

⑧

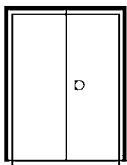

Measurements of all buildings:
141 x 202 x 250 mm
5.6 x 8.0 x 9.8 "





PLEASANTOWN COLLECTION

62214 Fire Station N° 9

⑨

62213 Post Office

⑩

62212 Sandy's Candies

⑪



PLEASANTOWN Qwik-Kits

The Qwik-Kit buildings come partially assembled, to give beautiful results in almost no time.

Windows, doors, signs and details are already installed.

62721 Music Shop

⑫

62722 Village Furniture

⑬

62723 Daily Grind Coffee House

⑭

62724 Book Worm Book Shop

⑮

Baseplate not included. We recommend the set of baseplates #62005 or the wooden sidewalks #62281 to enhance the model.

PIKO Built-Up models come factory-assembled, with signs installed, although in a few instances, certain parts may require simple final assembly, for safe transport in the package.



62707 Hill's Gingerbread House, Built-Up

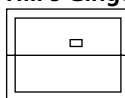

245 x 183 x 235 mm
9.7 x 7.2 x 9.3 "

62708 Washburn's Gingerbread House, Built-Up

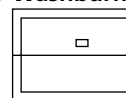

245 x 183 x 235 mm
9.7 x 7.2 x 9.3 "



62718 Railroad Tool Shed 2-Pack, Built-Up

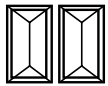

90 x 160 x 130 mm
3.5 x 6.3 x 5.1 "



62719 Outhouse 2-Pack, Built-Up

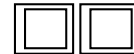

60 x 70 x 110 mm
2.4 x 2.8 x 4.3 "



Figures and accessories not included.

62725 Joe's Shoe Repair, Built-Up



240 x 230 x 200 mm
9.5 x 9.0 x 7.9 "

PIKO Built-Up models come factory-assembled, with signs installed, although in a few instances, certain parts may require simple final assembly, for safe transport in the package.

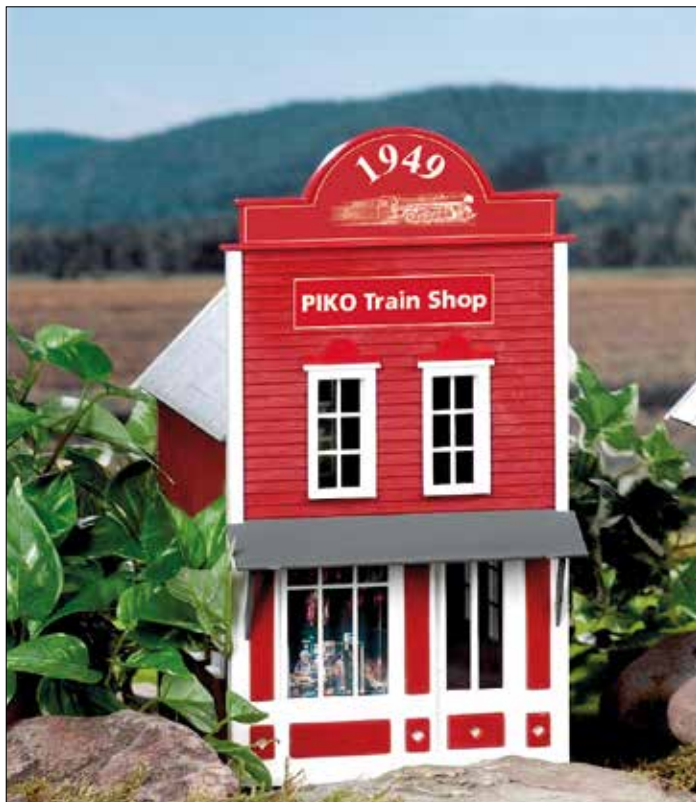

62705 PIKO Train Shop, Built-Up

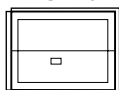

141 x 202 x 250 mm
5.6 x 8.0 x 9.8 "

62706 Wildwood Church, Built-Up

This attractive church with its picturesque little bell tower and porch is an ideal addition to any layout. The weather-resistant and slightly weathered model creates a truly American atmosphere. The doors can be opened and closed.

We recommend the baseplates #62005 to enhance the model (1 set).

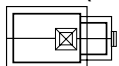

150 x 315 x 360 mm
5.9 x 12.4 x 14.2 "

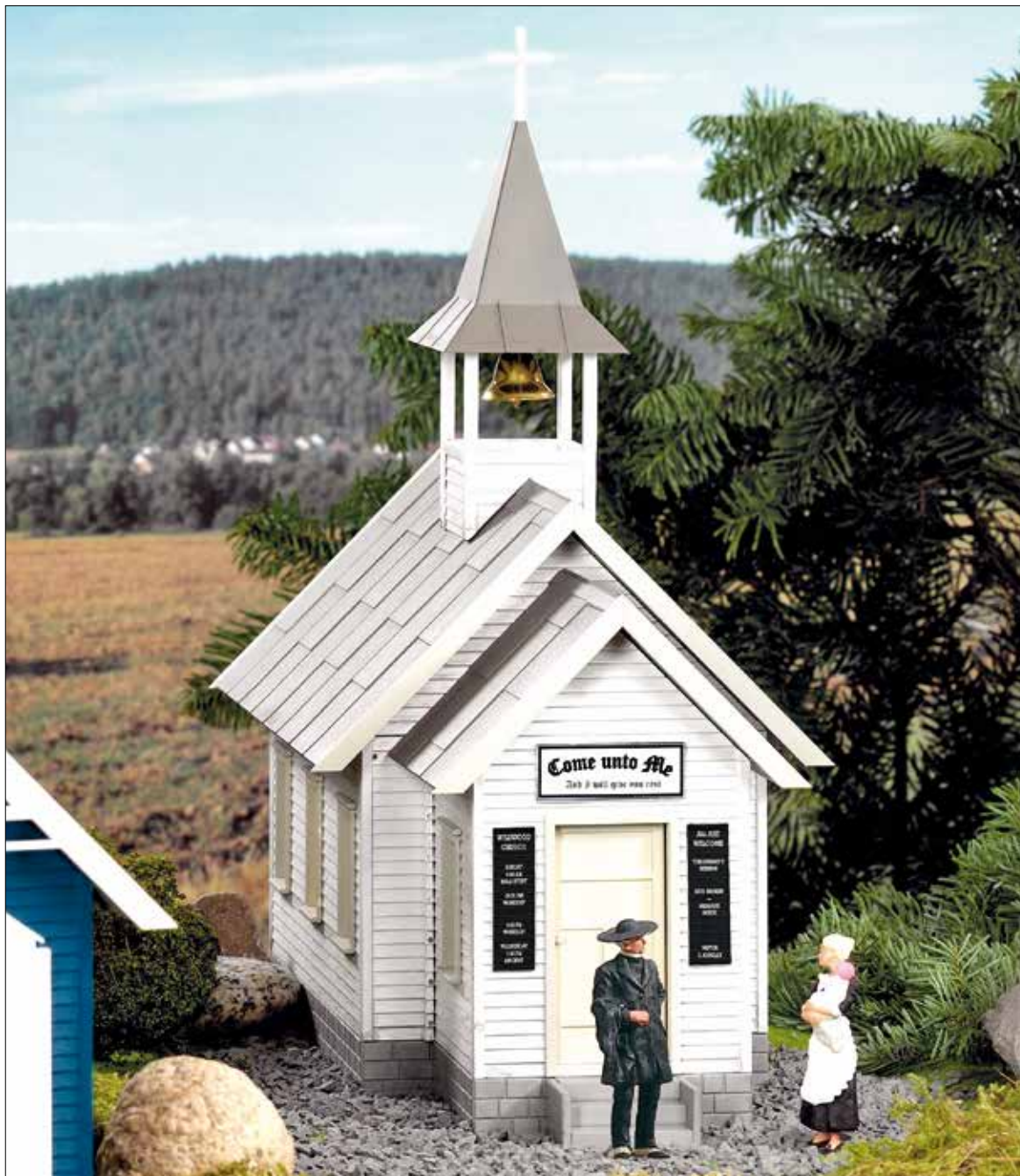

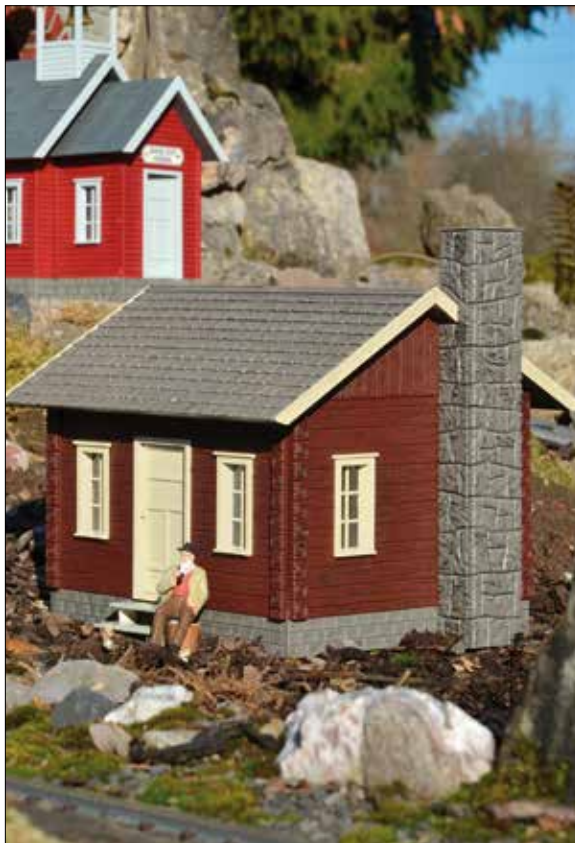

62716 River City Tommy's Cabin, Built-Up

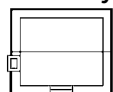

254 x 230 x 230 mm
10.0 x 9.1 x 9.1 "



62717 River City School House, Built-Up

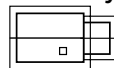

150 x 315 x 250 mm
5.9 x 12.4 x 9.8 "



62700 Green River Station, Built-Up

- ① The station comes pre-assembled. It can be disassembled easily and is weather-resistant as well as partially aged. The doors open.

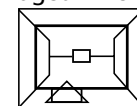

215 x 175 x 205 mm
8.5 x 6.9 x 8.1 "

62701 Old West Water Tower, Built-Up

- ② Built-Up model. The tank can be filled with water and emptied via the spout.



170 x 170 x 270 mm
6.7 x 6.7 x 10.6 "

PIKO Built-Up models come factory-assembled, with signs installed, although in a few instances, certain parts may require simple final assembly, for safe transport in the package.

Figures and accessories not included.

62726 River City, Buffalo Bill's Barber Shop, Built-Up

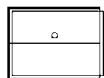

141 x 202 x 240 mm
5.6 x 8.0 x 9.5 "

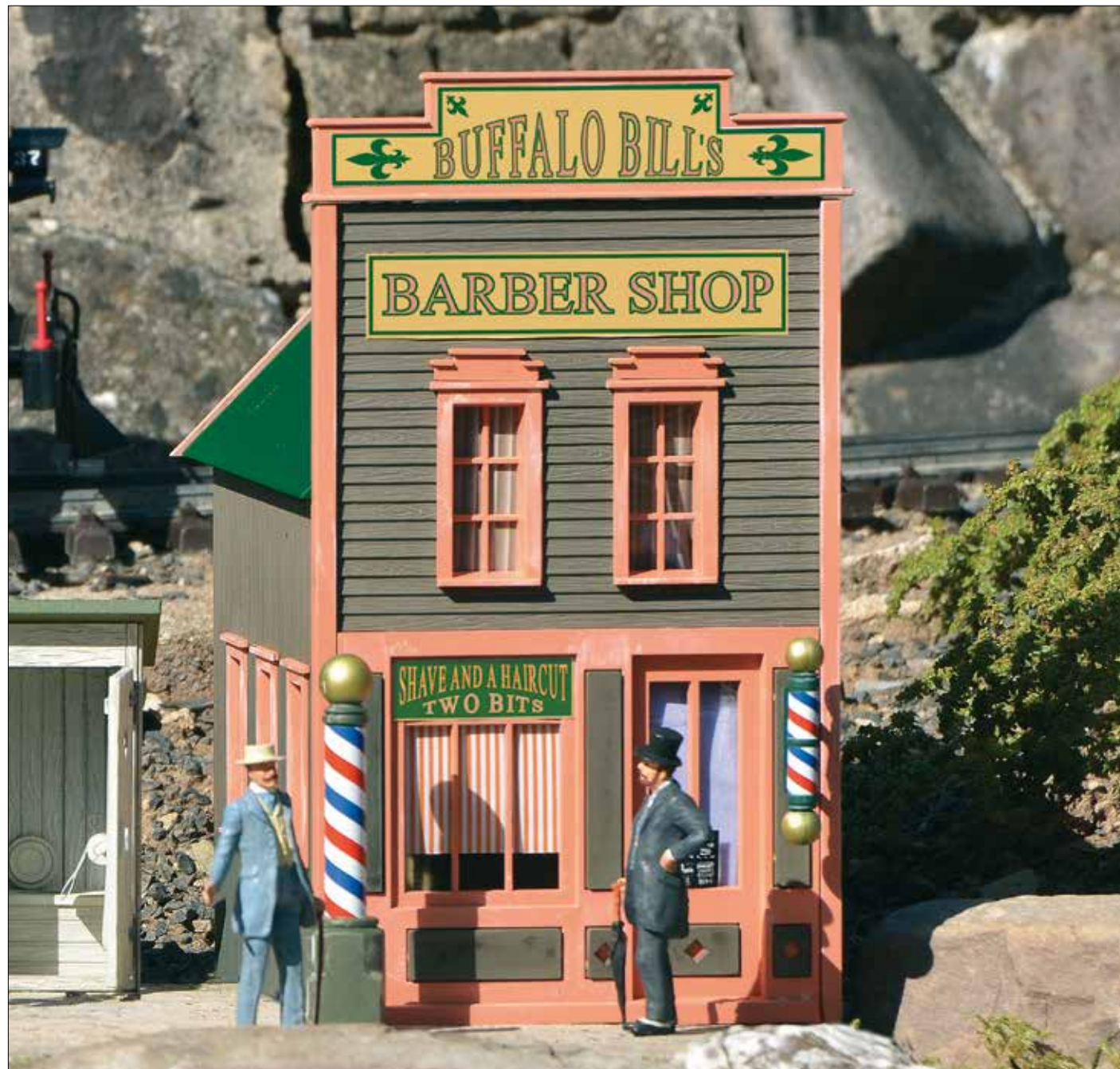

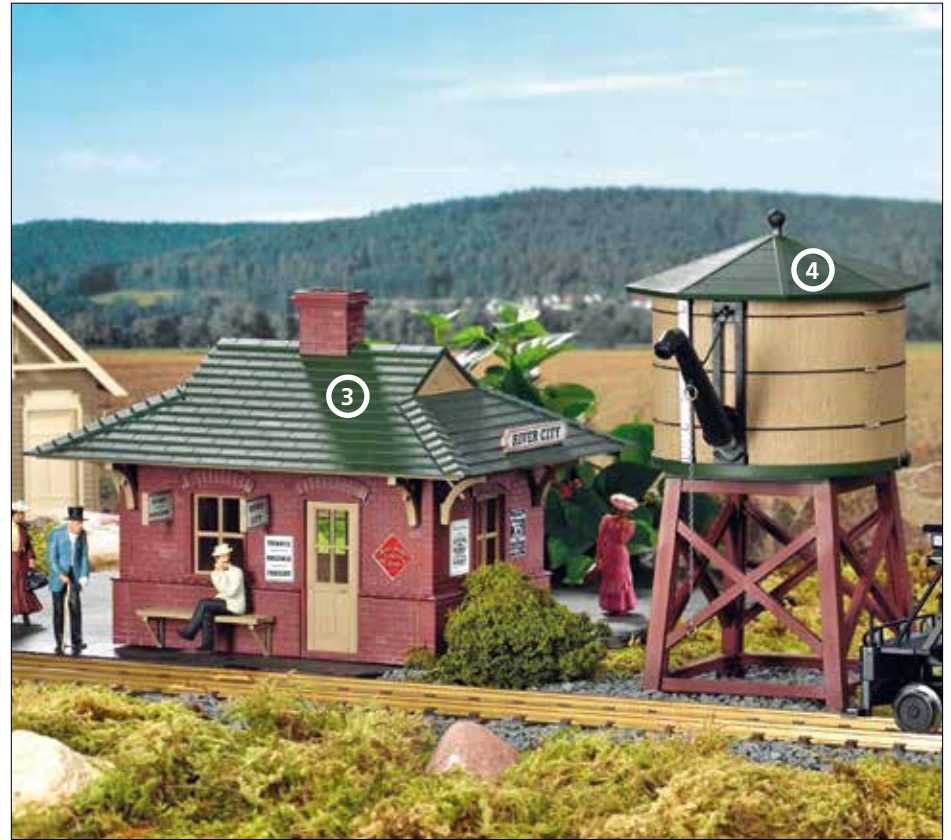

62714 River City Squires' Livery, Built-Up

①

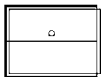

141 x 202 x 250 mm
5.6 x 8.0 x 9.8 "

62715 River City Shinn's Billiard Parlor, Built-Up

②



141 x 202 x 250 mm
5.6 x 8.0 x 9.8 "

62709 River City Station, Built-Up

③

The station comes pre-assembled. It can be disassembled easily and is weather-resistant as well as partially aged. The doors open.

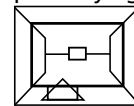

215 x 175 x 205 mm
8.5 x 6.9 x 8.1 "

62710 River City Water Tower, Built-Up

④

Built-Up model. The tank can be filled with water and emptied via the spout.

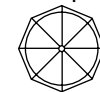

170 x 170 x 270 mm
6.7 x 6.7 x 10.6 "



62265 North Pole Station, Built-Up



215 x 175 x 205 mm
8.5 x 6.9 x 8.1 "

62702 North Pole Water Tank, Built-Up



170 x 170 x 270 mm
6.7 x 6.7 x 10.6 "



62703 Santa's House, Built-Up



183 x 245 x 235 mm
7.2 x 9.7 x 9.3 "



62814 Set of Icicles

2 pcs. 282 x 39 mm
2 pcs. 207 x 30 mm
8 pcs. 62 x 36 mm



The Pleasantown Collection Buildings can be assembled and disassembled easily due to their unique "pin" connector system.

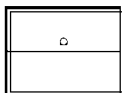

Measurements of all buildings:
141 x 202 x 250 mm
approx. 5.6 x 8.0 x 9.8 "

62200 Santa's Work Shop

①

62201 Robin's Toy Shop

②

62202 The Village Inn

③

62203 St. Thomas Church

④

A brass bell is included.

62800 - 62813 G Construction elements

In order to provide creative G scale enthusiasts with the means of kitbasing their own imaginative designs, PIKO offers the a variety of individual building parts.

| | | | | |
|-------|--------------|-------|--------------|--------------|
| 62800 | Doors | 2 x A | 218 x 206 mm | 8.6 x 8.1 " |
| | | 2 x B | 45 x 110 mm | 1.8 x 4.3 " |
| | | 2 x C | 76 x 101 mm | 3.0 x 4.0 " |
| 62801 | Metal Roof | 4 x | 224 x 240 mm | 8.8 x 9.5 " |
| 62802 | Shingle Roof | 2 x | 475 x 198 mm | 18.7 x 7.8 " |

62801 Metal Roofs



62802 Shingle Roof



62800 Doors

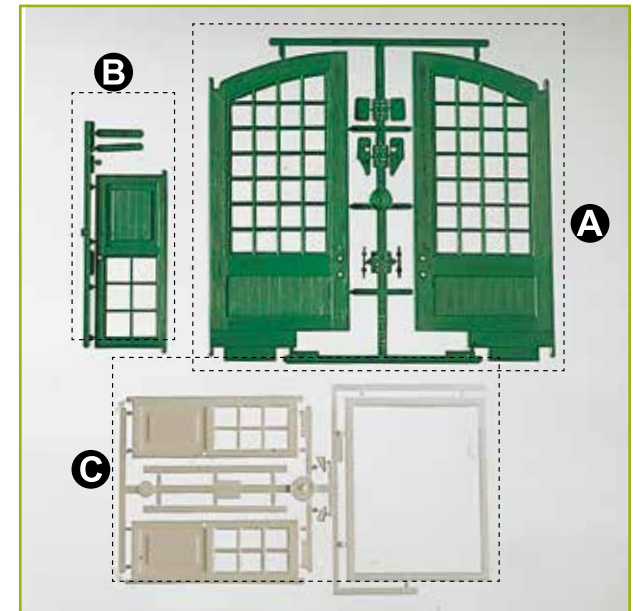

62803 Tiled Roofs

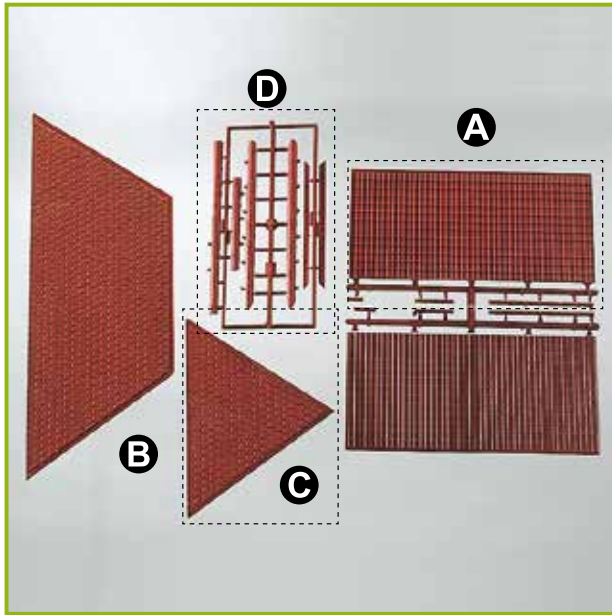

| | | | | |
|-------|--------------------------|---|--|--|
| 62803 | Tiled Roofs | 2 x A 2 x B 2 x C 2 x D | 287 x 137 mm 455 x 172 mm 235 x 172 mm | 11.3 x 5.4 " 17.9 x 6.8 " 9.3 x 6.8 " |
| 62804 | Windows of Brewery | 3 x A 3 x B 3 x C 3 x D 3 x E 6 x F | 44 x 96 mm 60 x 96 mm 44 x 96 mm 60 x 96 mm 95 x 27 mm Ø 26 mm | 1.7 x 3.8 " 2.4 x 3.8 " 1.7 x 3.8 " 2.4 x 3.8 " 3.8 x 1.0 " Ø 1.0 " |
| 62805 | Windows and Shutters | 6 x A 4 x B 4 x C 6 x D 2 x E 8 x F | 19 x 49 mm 22 x 76 mm 48 x 82 mm 35 x 48 mm Ø 21 mm 36 x 7 x 7 mm | 0.8 x 1.9 " 0.9 x 3.0 " 1.9 x 3.2 " 35 x 48 " Ø 0.8 " 1.4 x 0.3 x 0.3 " |
| 62806 | Sliding Windows and Door | 2 x A 4 x B 8 x C | 42 x 98 mm 38 x 50 mm 38 x 38 mm | 1.7 x 3.9 " 1.5 x 2.0 " 1.5 x 1.5 " |

62804 Windows of Brewery

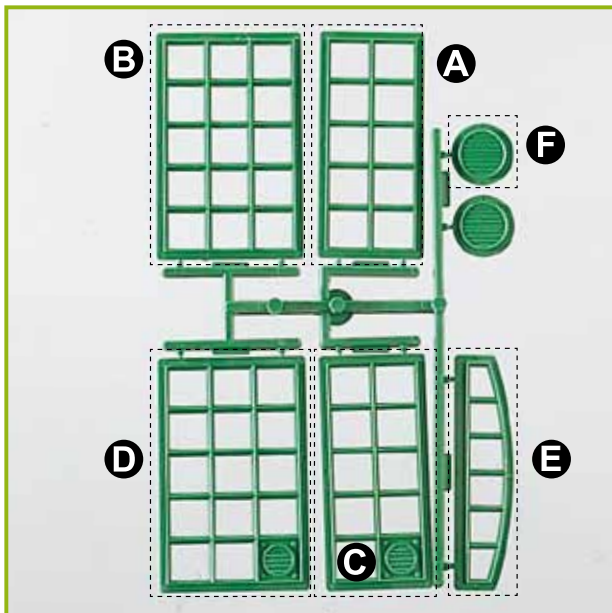

62805 Windows and Shutters

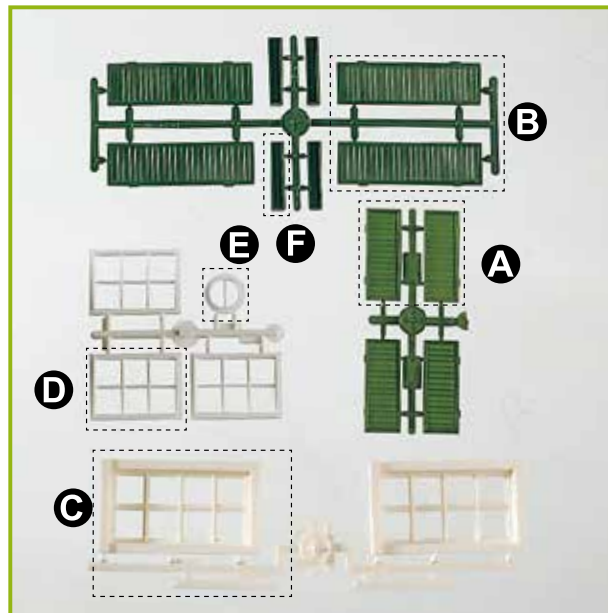

62806 Sliding Windows and Door

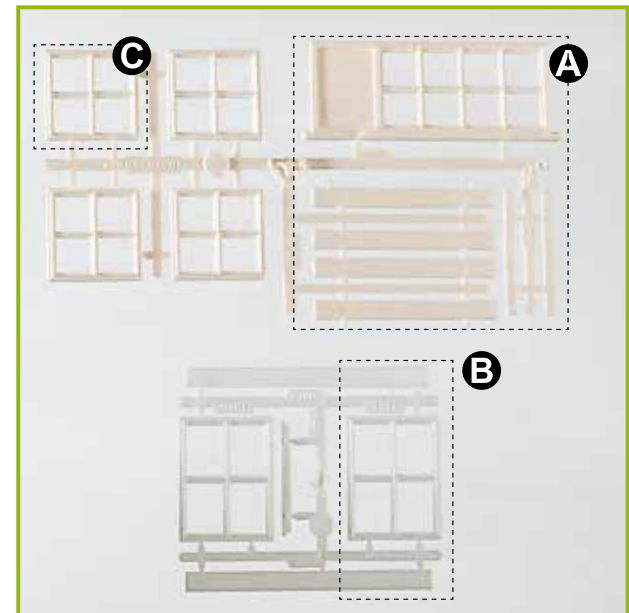

62807 Round Arch Windows

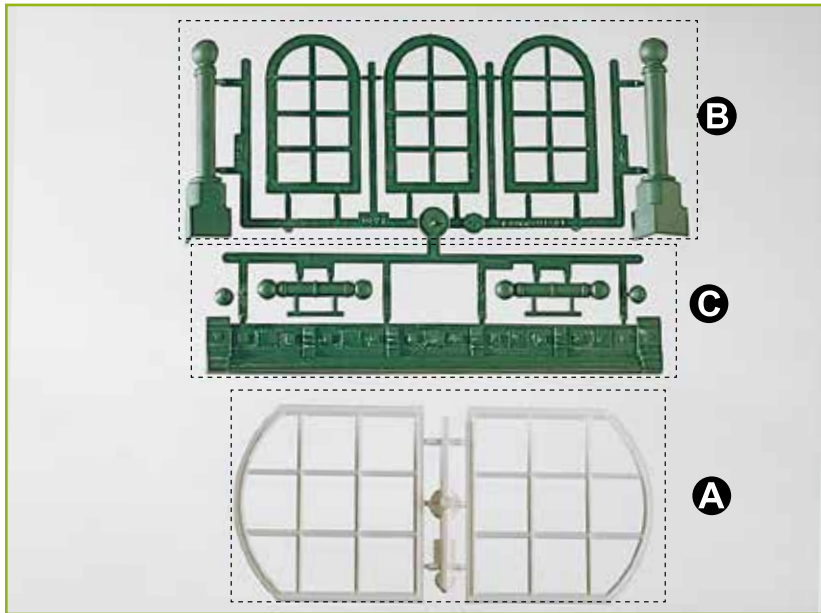

| | | | | |
|-------|--------------------|-------------------------|---|---|
| 62807 | Round Arch Windows | 2 x A 1 x B 1 x C | 94,5 x 90 mm 46 x 80 mm 218 x 28 mm | 3.7 x 3.5 " 1.8 x 3.2 " 8.6 x 1.1 " |
| 62808 | Corners of Brewery | 4 x A 4 x B 4 x C | 5 x 193 mm 20 x 193 mm 20 x 20 x 193 mm | 0.2 x 7.6 " 0.8 x 7.6 " 0.8 x 0.8 x 7.6 " including little parts |
| 62809 | US Brick Walls | 2 x A 1 x B 1 x C | 233 x 258 mm 218 x 258 mm 218 x 160 mm | 9.2 x 10.2 " 8.6 x 10.2 " 8.6 x 6.3 " |
| 62810 | Wooden Walls | 2 x A 2 x B | 233 x 258 mm 149 x 258 mm | 9.2 x 10.2 " 5.6 x 10.2 " |

62808 Corners of Brewery

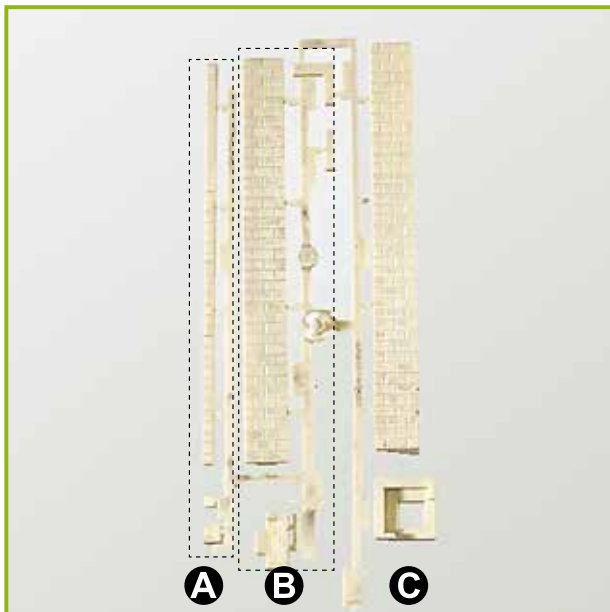

62809 US Brick Walls

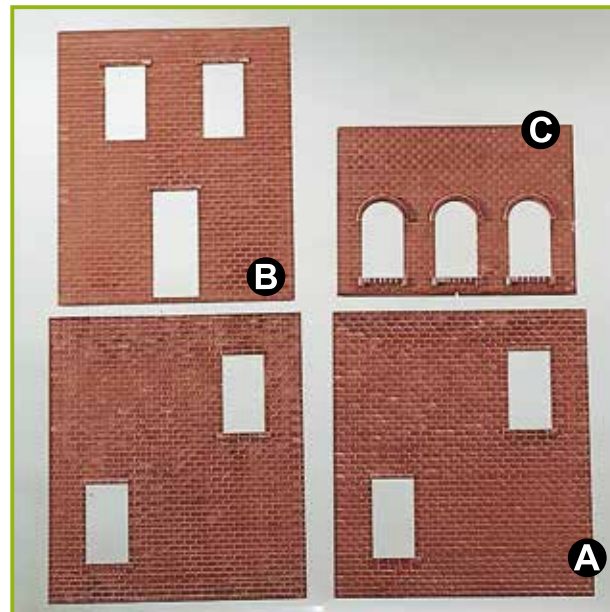

62810 Wooden Walls

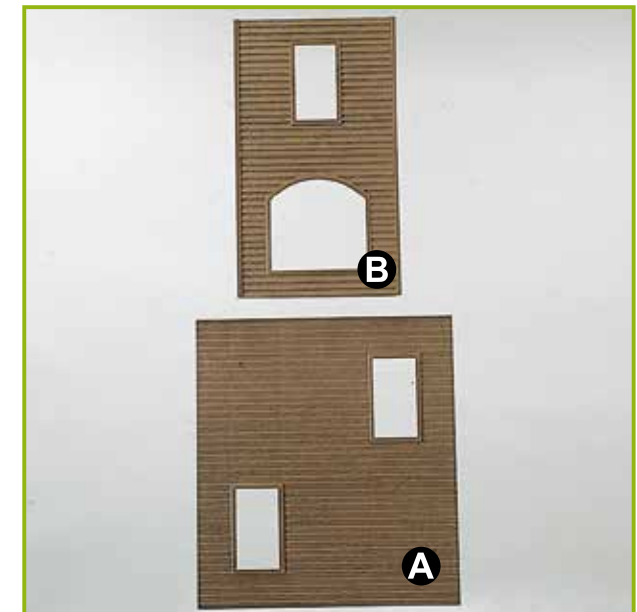

62811 Brewery Walls

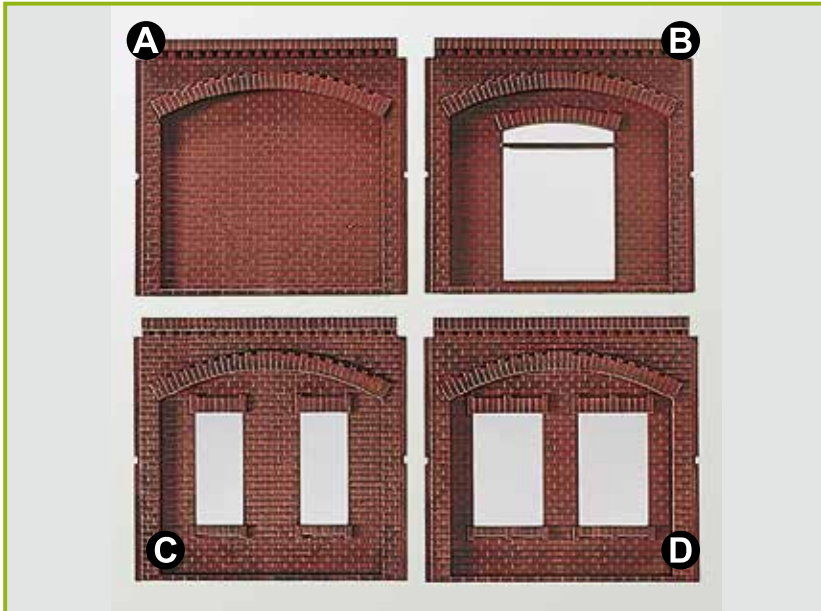

| | | | | |
|-------|---------------------|--|--|---|
| 62811 | Brewery Walls | 1 x A 1 x B 1 x C 1 x D | 219 x 209 mm 219 x 209 mm 219 x 209 mm 219 x 209 mm | 8.6 x 8.2 " 8.6 x 8.2 " 8.6 x 8.2 " 8.6 x 8.2 " |
| 62812 | Chimneys Assortment | 2 x A 2 x B 2 x C | | |
| 62813 | Window Glass | 4 x A 4 x B 12 x C 2 x D 2 x E | 61 x 95 mm 35 x 80 mm 33 x 33 mm 52 x 32 mm 96 x 28 mm | 2.4 x 3.7 " 1.4 x 3.1 " 1.3 x 1.3 " 2.0 x 1.3 " 3.8 x 1.1 " |

62813 Window Glasses

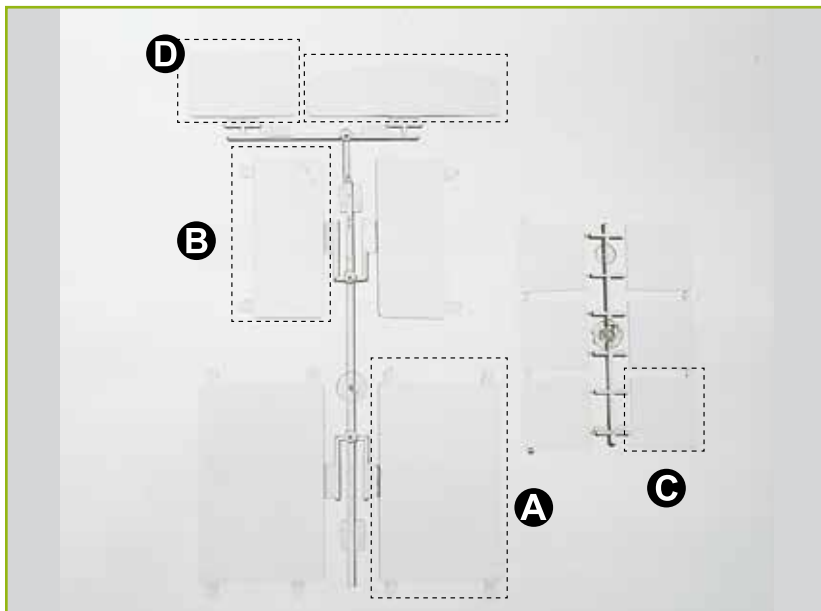

62812 Assorted Chimneys

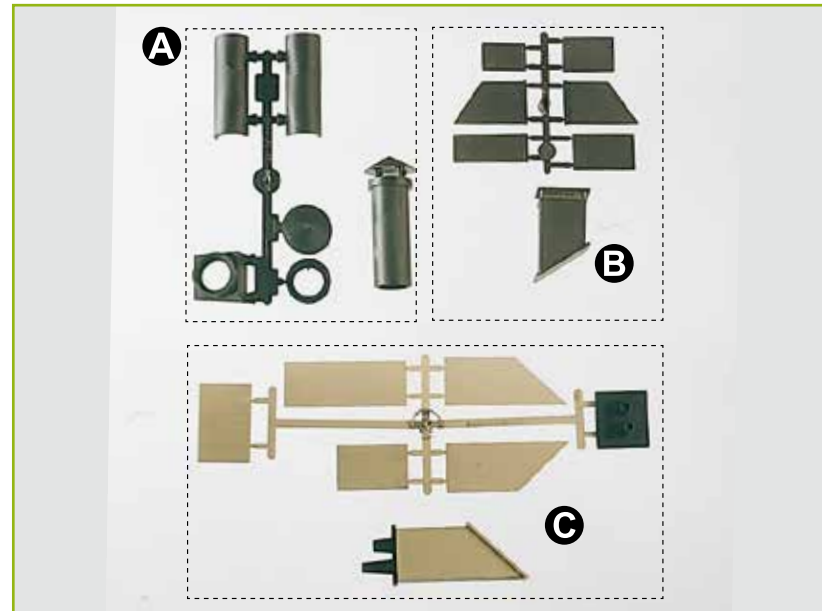

62280 Split Rail Fence

Fences made of split timbers are typical on North American farms. Eight sections with a total length of approximately 63".



62281 Wooden Sidewalks

Classic wooden sidewalks. An ideal addition to your Western town.



55701 PIKO-Fix Plastic Model Cemen

Needle-point dispenser for precise application. Strong solvent-type plastic model cement. Recommended for assembling all PIKO buildings, especially buildings for outdoor use.



62297 US Mail Box

Parts for 4 mailboxes included in Kit.

55757 Lights

4 Light Sockets with light bulbs 16 V, E 5,5 for use as indoor lighting in all G- and 1 Gauge buildings.



55758 Light Bulbs

10 pc. Light Bulbs 16 V for use in Interior Lights #55757.



62090 Street Lamp

Operating, weather-resistant street lamp with brass lamp post. Height: 13.4 "



62091 House Light

The finely detailed model is fully operational, weather-resistant, made partly out of brass and can be fitted easily to any building. Height: 1.6 "

| Item # | Page | Item # | Page | Item # | Page | Item # | Page | Item # | Page | Item # | Page | Item # | Page |
|--------|------|--------|------|--------|------|--------|------|--------|------|--------|------|--------|------|
| 38655 | 73 | 38902 | 87 | 62006 | 127 | 62056 | 133 | 62207 | 167 | 62247 | 159 | 62700 | 175 |
| 38656 | 73 | 38903 | 87 | 62007 | 132 | 62057 | 147 | 62208 | 162 | 62248 | 161 | 62701 | 175 |
| 38657 | 69 | 38906 | 96 | 62008 | 126 | 62058 | 149 | 62209 | 130 | 62249 | 161 | 62702 | 178 |
| 37658 | 69 | 38907 | 96 | 62009 | 143 | 62059 | 134 | 62210 | 130 | 62250 | 165 | 62703 | 178 |
| 37659 | 69 | 38909 | 87 | 62010 | 143 | 62064 | 146 | 62212 | 171 | 62251 | 154 | 62705 | 174 |
| 38660 | 69 | 38910 | 87 | 62011 | 143 | 62065 | 146 | 62213 | 171 | 62252 | 136 | 62706 | 174 |
| 38706 | 96 | 38911 | 85 | 62012 | 153 | 62066 | 146 | 62214 | 171 | 62253 | 136 | 62707 | 172 |
| 38732 | 92 | 38912 | 85 | 62013 | 139 | 62067 | 146 | 62215 | 170 | 62254 | 136 | 62708 | 172 |
| 38735 | 98 | 38913 | 85 | 62014 | 138 | 62068 | 146 | 62216 | 170 | 62256 | 163 | 62709 | 177 |
| 38740 | 93 | 38914 | 85 | 62015 | 139 | 62072 | 149 | 62217 | 170 | 62257 | 165 | 62710 | 177 |
| 38741 | 93 | 38916 | 88 | 62016 | 139 | 62073 | 149 | 62218 | 170 | 62258 | 165 | 62714 | 177 |
| 38747 | 84 | 38917 | 89 | 62017 | 139 | 62077 | 133 | 62219 | 167 | 62259 | 165 | 62715 | 177 |
| 38749 | 98 | 38918 | 89 | 62018 | 142 | 62078 | 164 | 62220 | 167 | 62260 | 169 | 62716 | 175 |
| 38751 | 92 | 38919 | 89 | 62019 | 142 | 62090 | 184 | 62221 | 161 | 62261 | 133 | 62717 | 175 |
| 38753 | 98 | 38921 | 87 | 62021 | 135 | 62091 | 184 | 62222 | 156 | 62262 | 157 | 62718 | 173 |
| 38754 | 98 | 38922 | 91 | 62022 | 148 | 62103 | 153 | 62223 | 158 | 62264 | 151 | 62719 | 173 |
| 38755 | 93 | 38923 | 91 | 62023 | 168 | 62104 | 153 | 62224 | 158 | 62265 | 178 | 62721 | 171 |
| 38756 | 93 | 38924 | 88 | 62028 | 164 | 62105 | 137 | 62225 | 158 | 62266 | 166 | 62722 | 171 |
| 38763 | 94 | 38925 | 87 | 62030 | 127 | 62106 | 137 | 62226 | 161 | 62267 | 166 | 62723 | 171 |
| 38764 | 92 | 38926 | 90 | 62032 | 128 | 62108 | 137 | 62227 | 166 | 62280 | 184 | 62724 | 171 |
| 38766 | 94 | 38931 | 86 | 62034 | 144 | 62109 | 134 | 62228 | 134 | 62281 | 184 | 62725 | 173 |
| 38773 | 94 | 38933 | 86 | 62035 | 144 | 62110 | 155 | 62229 | 160 | 62282 | 148 | 62726 | 176 |
| 38774 | 94 | 38934 | 89 | 62036 | 145 | 62111 | 152 | 62230 | 131 | 62283 | 153 | 62800 | 180 |
| 38775 | 84 | 38935 | 89 | 62037 | 140 | 62112 | 156 | 62231 | 131 | 62284 | 151 | 62801 | 180 |
| 38778 | 95 | 38940 | 87 | 62038 | 140 | 62113 | 129 | 62232 | 129 | 62285 | 135 | 62802 | 180 |
| 38779 | 95 | 38941 | 91 | 62039 | 140 | 62114 | 164 | 62233 | 162 | 62286 | 151 | 62803 | 181 |
| 38781 | 84 | 38942 | 91 | 62044 | 133 | 62116 | 152 | 62234 | 170 | 62287 | 145 | 62804 | 181 |
| 38782 | 84 | 38945 | 97 | 62046 | 141 | 62117 | 150 | 62235 | 170 | 62288 | 139 | 62805 | 181 |
| 38825 | 90 | 38946 | 97 | 62047 | 141 | 62118 | 150 | 62236 | 170 | 62289 | 139 | 62806 | 181 |
| 38829 | 88 | 38947 | 97 | 62048 | 141 | 62119 | 150 | 62237 | 170 | 62290 | 140 | 62807 | 182 |
| 38831 | 90 | 38948 | 96 | 62049 | 141 | 62120 | 155 | 62238 | 163 | 62291 | 155 | 62808 | 182 |
| 38862 | 96 | 55701 | 184 | 62050 | 147 | 62200 | 179 | 62239 | 163 | 62293 | 151 | 62809 | 182 |
| 38873 | 90 | 55757 | 184 | 62051 | 148 | 62201 | 179 | 62240 | 163 | 62294 | 151 | 62810 | 182 |
| 38879 | 90 | 55758 | 184 | 62052 | 148 | 62202 | 179 | 62242 | 154 | 62295 | 156 | 62811 | 183 |
| 38880 | 88 | 62001 | 132 | 62053 | 147 | 62203 | 179 | 62243 | 163 | 62296 | 129 | 62812 | 183 |
| 38885 | 90 | 62002 | 132 | 62054 | 190 | 62204 | 167 | 62246 | 159 | 62297 | 184 | 62813 | 183 |

| Item # | Page |
|--------|------|
| 62814 | 178 |

WITH PIKO, YOU'RE ON THE TRACK TO FUN!

PIKO

In 2022, PIKO again offers you a wide selection of models from America and Europe.

Our goal is to deliver the enjoyment of G-Scale trains to PIKO fans new and old, around the world.

With PIKO, you're on the track to fun!



BR 50 Reko DR IV 
> See page 57



PRR Freight R/C Starter 
> See page 12



DR IV-V BR 95 Steam Loco 
> See page 48



D&RGW Mogul 
> See page 41



DR III BR 24 Steam Loco 
> See page 45



Another 1st, only from PIKO! 25-Ton diesel locos factory-equipped for full battery-powered operation, with PIKO R/C and realistic digital sound built-in. Run the train over any track, ring the bell, blow the horn - all controlled from the easy and convenient Pocket Remote included with the loco. See page 37 for more details.



Our 38109 SF Freight R/C Starter Set comes complete with an 0-6-0T steam loco, two freight cars, a circle of PIKO G-Track, and the convenience of PIKO R/C control with a pocket remote.

See page 13



Our new 38234 D&RGW Mogul #214 features great-working smoke, directional lights, and a fantastic digital sound system, with extensive features on Analog DC as well as DCC operation. See page 41



PIKO Spielwaren GmbH | Lutherstraße 30 | 96515 Sonneberg, Germany
Tel. +49 (3675) 8972 - 42 | Fax +49 (3675) 8972 - 50 | hotline@piko.de
www.piko.de PIKO® ist ein eingetragenes Warenzeichen.



PIKO America LLC | 4610 Alvarado Canyon Rd., Suite 5 | San Diego CA 92120
Phone 619-280-2800 | Toll-Free 877-678-4449 | support@piko-america.com
www.piko-america.com PIKO® is a registered Trademark. All rights reserved.

www.piko.de

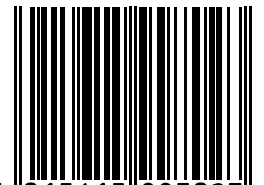

4 015615 997023

99702US 2022 © PIKO Spielwaren GmbH